

Related Rates - Classwork

Earlier in the year, we used the basic definition of calculus as “the mathematics of change.” We defined words that meant change: increasing, decreasing, growing, shrinking, etc. Change occurs over time. So, when we talk about how a quantity changes, we are talking about the derivative of that quantity with respect to time.

Example 1) Write the following statements mathematically.

- a) John is growing at the rate of 3 inches/year. b) My mutual fund is shrinking by 4 cents/day.
- c) The radius of a circle is increasing by 4 ft/hr. d) The volume of a cone is decreasing by $2 \text{ in}^3/\text{sec}$.

Example 2) A rectangle is 10 inches by 6 inches whose sides are changing. Write formulas for both the perimeter and area and how fast each is changing in terms of L and W .

Perimeter *Change of perimeter* *Area* *Change of area*

- a. its length and width are increasing at the rate of 2 inches/sec. b. its length and width are decreasing at the rate of 2 inches/sec.

Change of perimeter *Change of area* *Change of perimeter* *Change of area*

- c. its length is increasing at 3 inches/sec and the width is decreasing at 3 inches/sec. d. its length is decreasing at the rate of 2 inches/sec and its width is increasing at .5 inches/sec.

Change of perimeter *Change of area* *Change of perimeter* *Change of area*

Example 3) A right triangle has sides of 30 and 40 inches whose sides are changing. Write formulas for the area of the triangle and the hypotenuse of the triangle and how fast the area and hypotenuse are changing

Area *Change of area* *Hypotenuse* *Change of hypotenuse*

- a) the short side is increasing at 3 in./sec and the long side is increasing at 5 in./sec. b) the short side is increasing at 3 in./sec and the long side is decreasing at 5 in./sec.

Change of area *Change of hypotenuse* *Change of area* *Change of hypotenuse*

Example 4. A right circular cylinder has a height of 10 feet and radius 8 feet whose dimensions are changing. Write formulas for the volume and surface area of the cylinder and the rate at which they change.

<i>Volume</i>	<i>Change of volume</i>	<i>Surface area</i>	<i>Change of surface area</i>
---------------	-------------------------	---------------------	-------------------------------

a) the radius is growing at 2 feet/min and the height is shrinking at 3 feet/min.

b) the radius is decreasing at 4 feet/min and the height is increasing at 2 feet/min.

Change of volume

Change of surface area

Change of volume

Change of surface area

To solve related rates problems, you need a strategy that always works. Related rates problems always can be recognized by the words “increasing, decreasing, growing, shrinking, changing.” Follow these guidelines in solving a related rates problem.

1. Make a sketch. Label all sides in terms of variables even if you are given the actual values of the sides.
2. You will make a table of variables. The table will contain two types of variables - variables that are constants and variables that are changing. Variables that never change go into the constant column. Variables that are a given value only at a certain point in time go into the changing column. Rates (recognized by “increasing”, “decreasing”, etc.) are derivatives with respect to time and can go in either column.
3. Find an equation which ties your variables together. If it an area problem, you need an area equation. If it is a right triangle, the Pythagorean formula may work or general trig formulas may apply. If it is a general triangle, the law of cosines may work.
4. You may now plug in any variable in the constant column. **Never** plug in any variable in the changing column.
5. Differentiate your equation with respect to time. You are doing implicit differentiation with respect to t .
6. Plug in all variables. Hopefully, you will know all variables except one. If not, you will need an equation which will solve for unknown variables. Many times, it is the same equation as the one you used above. Do this work on the side as to not destroy the momentum of your work so far.
7. Label your answers in terms of the correct units (very important) and be sure you answered the question asked.

Example 5) An oil tanker spills oil that spreads in a circular pattern whose radius increases at the rate of 50 feet/min. How fast are both the circumference and area of the spill increasing when the radius of the spill is a) 20 feet and b) 50 feet?

Example 6) A 13 foot ladder leans against a vertical wall. If the lower end of the ladder is pulled away at the rate 2 feet per second, how fast is the top of the ladder coming down the wall at a) the instant the top is 12 feet above the ground and b) 5 feet above the ground?

Example 7) A camera is mounted 3,000 feet from the space shuttle launching pad. The camera needs to pivot as the shuttle is launched and needs to keep the shuttle in focus. If the shuttle is rising vertically at 800 feet/sec when it is 4,000 feet high, how fast is the camera-to-shuttle distance changing?

In this problem, how fast is the angle of elevation of the camera changing at that moment in time?

What variable are we trying to find? _____ Since this is a function of θ , we need a trig function. There are three trig functions we could use. Let's try all three and determine which is best.

$$\sin \theta = \frac{y}{z}$$

$$\cos \theta = \frac{x}{z}$$

$$\tan \theta = \frac{y}{x}$$

Example 8) Two cars are riding on roads that meet at a 60° angle. Car A is 3 miles from the intersection traveling at 40 mph and car B is 2 miles away from the intersection traveling at 50 mph. How fast are the two cars separating if a) they are both traveling away from the intersection and b) car A is traveling away from the intersection and car B is traveling towards it?

Example 9) Sand is poured on a beach creating a cone whose radius is always equal to twice its height. If the sand is poured at the rate of $20 \text{ in}^3/\text{sec}$, How fast is the height changing at the time the height is a) 2 inches, b) 6 inches?

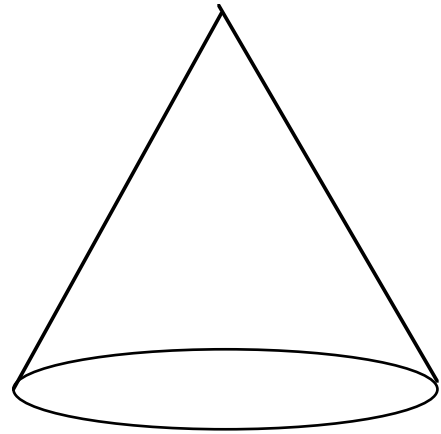

Example 10) Water is draining from a conical tank at the rate of $2 \text{ meter}^3/\text{sec}$. The tank is 16 meters high and its top radius is 4 meters. How fast is the water level falling when the water level is a) 12 meters high, b) 2 meters high?

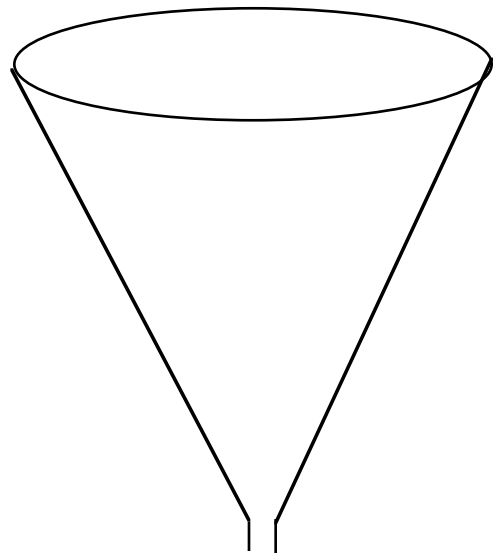

Related Rates - Homework

1. A circle has a radius of 8 inches which is changing. Write formulas for its circumference and area.

Circumference

Change of circumference

Area

Change of area

- a) its radius is growing at the rate of 3 in./min.

- b) its radius is shrinking at the rate of $\frac{1}{4}$ inch/sec.

Change of circumference

Change of area

Change of circumference

Change of area

- c) its diameter is growing at the rate of 4 yd/min.

- d) its radius is shrinking at the rate of 1 inch/sec.

Change of circumference

Change of area

Change of circumference

Change of area

2. A sphere has a radius of 9 feet which is changing. Write formulas for its volume and surface area.

Volume

Change of volume

Surface area

Change of surface area

- a) its diameter is growing at the rate of 1 yd/min.

- b) its radius is shrinking at the rate of $\frac{3}{4}$ inch/sec.

Change of volume

Change of surface area

Change of volume

Change of surface area

3. A right circular cone has a height of 10 feet and radius 6 feet, both of which are changing. Write a formula for the volume of the cone.

Volume

Change of volume

- a) the radius grows at 6 ft/sec, the height shrinks at 12 in/sec

Change of volume

- b) the diameter is shrinking at 6 ft/sec and the height is growing at 2 ft/sec.

Change of volume

4. A rectangular well is 6 feet long, 4 feet wide, and 8 feet deep. If water is running into the well at the rate of $3 \text{ ft}^3/\text{sec}$, find how fast the water is rising (keep in mind which variables are constant and which are changing).
5. A spherical hot air balloon is being inflated. If air is blown into the balloon at the rate of $2 \text{ ft}^3/\text{sec}$,
- find how fast the radius of the balloon is changing when the radius is 3 feet.
 - find how fast the surface area is increasing at the same time.
6. A 12 foot ladder stands against a vertical wall. If the lower end of the ladder is being pulled away from the wall at the rate of $2 \text{ ft}/\text{sec}$,
- how fast is the top of the ladder coming down the wall at the instant it is 6 feet above the ground?
 - how fast is the angle of the elevation of the ladder changing at the same instant?
7. Superman is in level flight 6 miles above ground. His flight plan takes him directly over Wissahickon High. How fast is he flying when the distance between him and WHS is exactly 10 miles and this distance is increasing at the rate of 40 mph?
8. Two roads meet at an angle of 60° . A man starts from the intersection at 1 PM and walks along one road at 3 mph. At 2:00 PM, another man starts along the second road and walks at 4 mph. How fast are they separating at 4 PM?

9. A boy flies a kite which is 120 ft directly above his hand. If the wind carries the kite horizontally at the rate of 30 ft/min, at what rate is the string being pulled out when the length of the string is 150 ft?

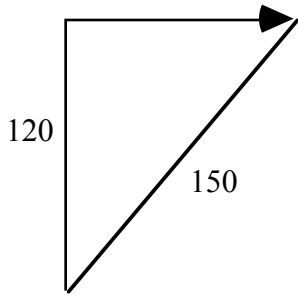

10. The same boy flies a kite which is now 100 feet above the ground. If the string is pulled out at the rate of 10 ft/sec because the wind carries the kite horizontally directly away from the boy, what is the rate of change of the angle the kite makes with the vertical when the angle is 30° .

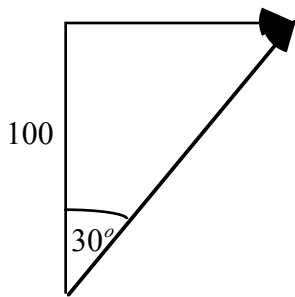

11. A baseball diamond is a 90-foot square. A ball is batted along the third-base line at a constant rate of 100 feet per second. How fast is its distance changing from first base at the time when a) the ball is halfway to 3rd base and b) it reaches 3rd base.

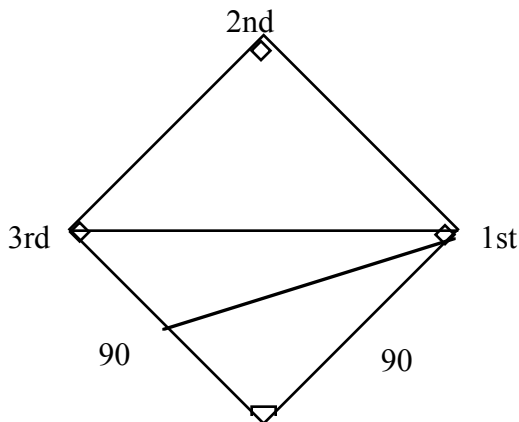

12. A plane is flying west at 500 ft/sec at an altitude of 4,000 ft. The plane is tracked by a searchlight on the ground. If the light is to be trained on the plane, find the change in the angle of elevation of the searchlight at a horizontal distance of 2,000 ft.

13. A revolving light located 5 miles from a straight shore line turns with a constant angular velocity. What velocity does the light revolve if the light moves along the shore at the rate of 15 miles per minute when the beam makes an angle of 60° with the shore line?

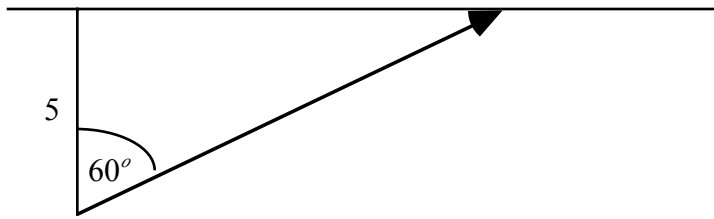

14. How fast does the radius of a spherical soap bubble change when you blow air into it at the rate of $10 \text{ cm}^3/\text{sec}$ at the time when the radius is 2 cm?
15. How fast does the water level drop when a cylindrical tank of radius 6 feet is drained at the rate of $3 \text{ ft}^3/\text{min}$?
16. A hot air balloon, rising straight up from a level field, is tracked by a range finder 500 feet from the lift-off point. At the moment the range finder's elevation angle is $\frac{\pi}{4}$, the angle is increasing at the rate of 0.14 radians/min. How fast is the balloon rising?

17. Water runs into a conical tank at the rate of $9 \text{ ft}^3/\text{min}$. The tank stands vertex down and has a height of 10 feet and a base radius of 5 feet. How fast is the water level rising when the water is 6 feet deep? (*Hint: use the picture and the variables shown below*)

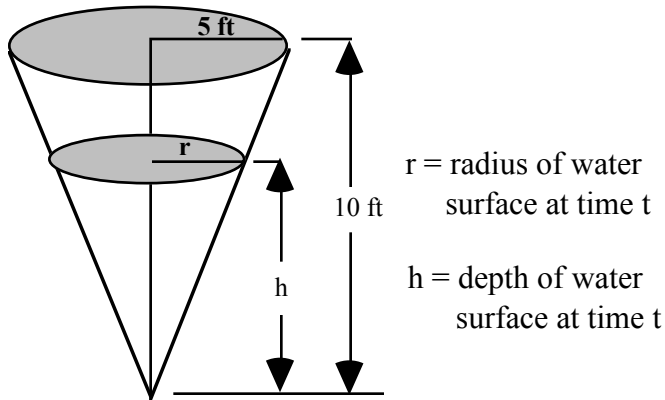

18. Two truck convoys leave a depot at the same time. Convoy A travels east at 40 mph and convoy B travels north at 30 mph. How fast is the distance between the convoys changing a) 6 minutes later, b) 30 minutes later.
19. Two commercial jets at 40,000 ft. are both flying at 520 mph towards an airport. Plane A is flying south and is 50 miles from the airport while Plane B is flying west and is 120 miles from the airport. How fast is the distance between the two planes changing at this time?
20. A spherical Tootsie Roll Pop that you are enjoying is giving up volume at a steady rate of $0.25 \text{ in}^3/\text{min}$. How fast will the radius be decreasing when the Tootsie Roll Pop is .75 inches across?

21. The mechanics at Toyota Automotive are reboring a 6-inch deep cylinder to fit a new piston. The machine that they are using increases the cylinder's radius one-thousandth of an inch every 3 minutes. How rapidly is the cylinder volume increasing when the bore (diameter) is 3.80 inches?

22. Sand falls at the rate of $30 \text{ ft}^3/\text{min}$ onto the top of a conical pile. The height of the pile is always $\frac{3}{8}$ of the base diameter. How fast is the height changing when the pile is 12 ft. high?

23. A rowboat is pulled toward a dock from the bow through a ring on the dock 6 feet above the bow. If the rope is hauled in at $2 \text{ ft}/\text{sec}$, how fast is the boat approaching the dock when 10 feet of rope are out?

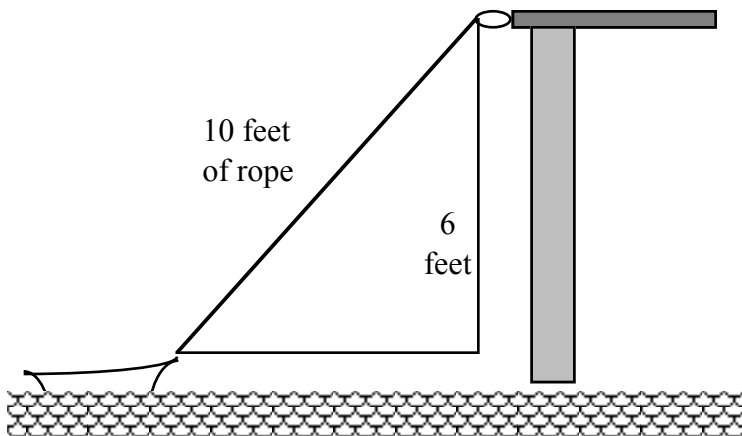

24. A particle is moving along the curve whose equation is $\frac{xy^3}{1+y^2} = \frac{8}{5}$. Assume the x -coordinate is increasing at the rate of 6 units/sec when the particle is at the point $(1, 2)$. At what rate is the y -coordinate of the point changing at that instant. Is it rising or falling?

25. A balloon is rising vertically above a level, straight road at a constant rate of 1 foot/sec. Just when the balloon is 65 feet above the ground, a bicycle passes under it going 17 feet/sec. How fast is the distance between the bicycle and balloon increasing 3 seconds later?

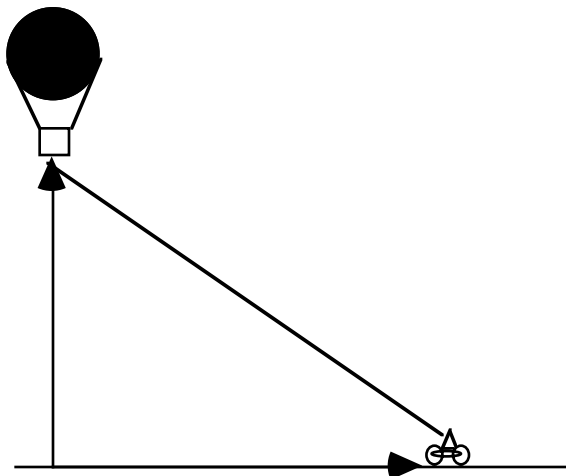

26. Coffee is draining from a conical filter into a cylindrical coffeepot at the rate of $10 \text{ in}^3/\text{min}$. a) How fast is the level in the pot rising when the coffee in the filter is 5 inches deep? b) How fast is the level in the cone falling then?

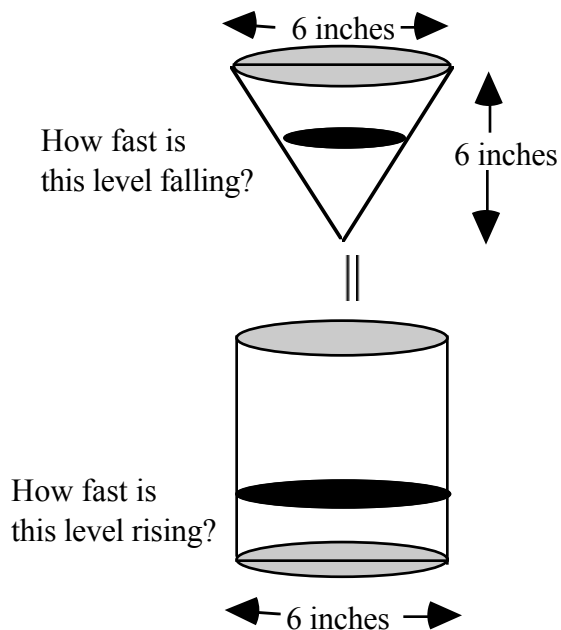

27. On a certain clock, the minute hand is 4 in. long and the hour hand is 3 in. long. How fast is the distance between the tips of the hands changing at 4 P.M?

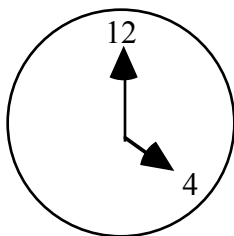

Straight Line Motion - Classwork

Consider an object moving along a straight line, either horizontally or vertically. There are many such objects, natural, and man-made. Write down several of them.

Horizontal _____ Vertical _____

As an object moves, its position is a function of time. For its position function, we will denote the variable $s(t)$. For instance, when $s(t) = t^2 - 2t - 3$, t in seconds, $s(t)$, we are being told what position on the horizontal or vertical number line the particle occupies at different values of t .

Example 1) For $s(t) = t^2 - 2t - 3$, show its position on the number line for $t = 0, 1, 2, 3, 4$.

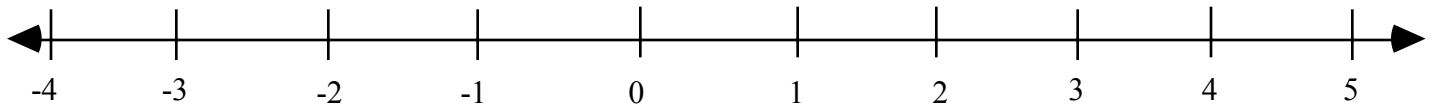

When an object moves, its position changes over time. So we can say that the velocity function, $v(t)$ is the change of the position function over time. We know this to be a derivative, and can thus say that $v(t) = s'(t)$.

For convenience sake, we will define $v(t)$ in the following way.

Motion	$v(t) > 0$	$v(t) < 0$	$v(t) = 0$
Horizontal Line	object moves to the right	object moves to the left	object stopped
Vertical Line	object moves up	object moves down	object stopped

Speed is not synonymous with velocity. Speed does not indicate direction. So we define the speed function: $\text{speed} = |v(t)|$. The speed of an object must either be positive or zero (meaning that the object is stopped).

The definition of acceleration is the change of velocity over time. We know this to be a derivative and can thus say that $a(t) = v'(t) = s''(t)$. So given the position function $s(t)$, we can now determine both the velocity and acceleration function. On your cars, you have two devices to change the velocity: _____. Let us think as something accelerating the object to be some external force like wind or current. For convenience sake, let us define the acceleration function like this:

Motion	$a(t) > 0$	$a(t) < 0$	$a(t) = 0$
Horizontal Line	object accelerating to the right	object accelerating to the left	velocity not changing
Vertical Line	object accelerating upwards	object accelerating downwards	velocity not changing

Just because an object's acceleration is zero does not mean that the object is stopped. It means that the velocity is not changing. What device do you have on your cars that keeps the car's acceleration equal to zero? _____

Also, just because you have a positive acceleration does not mean that you are moving to the right. For instance, suppose you were walking to the right [$v(t) > 0$], when all of a sudden a large wind started to blow to the left [$a(t) < 0$]. What would that do to your velocity? _____

Example 2) Given that a particle is moving along a horizontal line with position function $s(t) = t^2 - 4t + 2$.

The velocity function $v(t) = \underline{\hspace{2cm}}$ and the acceleration function $a(t) = \underline{\hspace{2cm}}$

Let's complete the chart for the first 5 seconds and show where the object is on the number line.

t	$s(t)$	$v(t)$	$ v(t) $	$a(t)$	Description of the particle's motion
0					
1					
2					
3					
4					
5					

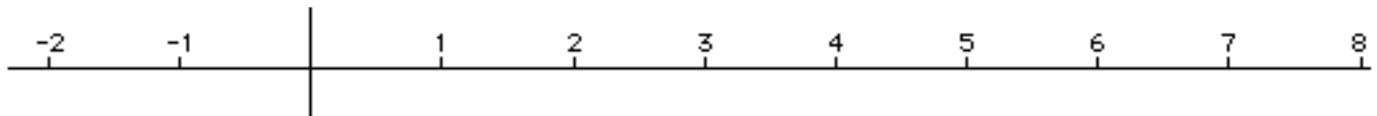

It is too much work to do such work for complicated functions. We are generally interested when the particle is stopped or when it has no acceleration. We are also interested when the object is speeding up or slowing down. Realizing that an object's velocity is either, positive (moving right), negative (moving left) or zero (stopped) and an object's acceleration is either positive, negative, or zero (constant speed), we can now use a chart to determine all the possibilities of an object's motion as if you were looking at it from above.

	$a(t) > 0$	$a(t) < 0$	$a(t) = 0$
$v(t) > 0$			
$v(t) < 0$			
$v(t) = 0$			

Example 3) A particle is moving along a horizontal line with position function $s(t) = t^2 - 6t + 5$. Do an analysis of the particle's direction (right, left), acceleration, motion (speeding up, slowing down), & position.

Step 1: $v(t) = \underline{\hspace{2cm}}$ So $v(t) = 0$ at $t = \underline{\hspace{2cm}}$

Step 2: Make a number line of $v(t)$ showing when the object is stopped and the sign and direction of the object at times to the left and right of that. Assume $t > 0$.

$v(t) \mid \underline{\hspace{10cm}}$
0

Step 3: $a(t) = \underline{\hspace{2cm}}$. Does $a(t) = 0$? $\underline{\hspace{2cm}}$

Step 4: Make a number line of $a(t)$ showing when the object has a positive and negative acceleration. Scale it exactly like the $v(t)$ number line.

$a(t) \mid \underline{\hspace{10cm}}$
0

Step 5: Make a motion line directly below the last two putting all critical values, multiplying the signs and interpreting according to the chart above.

motion $\mid \underline{\hspace{10cm}}$
0

Step 6: Make a position graph to show where the object is at critical times and how it moves.

position $\underline{\hspace{10cm}}$

Example 4) A particle is moving along a horizontal line with position function $s(t) = t^3 - 9t^2 + 24t + 4$. Do an analysis of the particle's direction, acceleration, motion (speeding up or slowing down), and position.

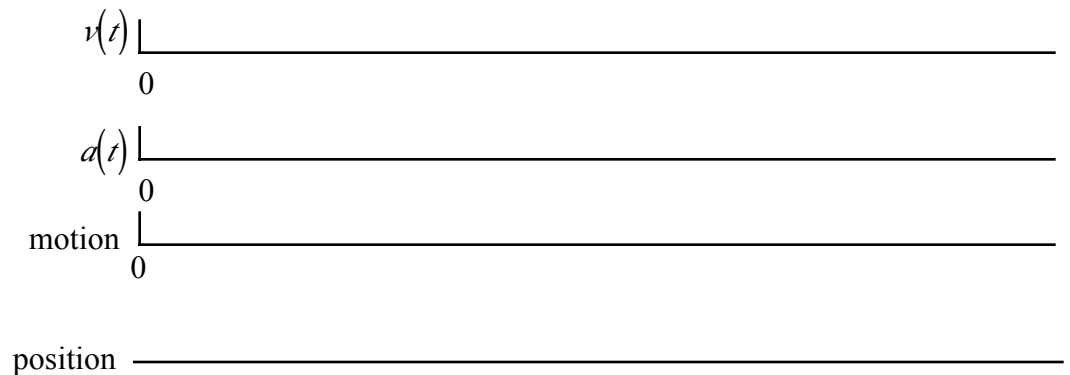

Note that the position graph is not like the other three graphs. It simply shows the position the object has with respect to the origin and critical times of its movement found by setting $v(t)$ and $a(t) = 0$.

When an object is subjected to gravity, its position function is given by $s(t) = -16t^2 + v_0t + s_0$, where t is measured in seconds, $s(t)$ is measured in feet, v_0 is the initial velocity (velocity at $t = 0$) and s_0 is the initial position (position at $t = 0$). The formula is given by $s(t) = -4.9t^2 + v_0t + s_0$ if $s(t)$ is measured in meters.

From our original $s(t) = -16t^2 + v_0t + s_0$, we can calculate the velocity function $v(t) = \underline{\hspace{2cm}}$ and the acceleration function $a(t) = \underline{\hspace{2cm}}$. This is the acceleration due to gravity on earth.

When an object is thrown upward, it is subjected to gravity, We are usually interested how high the particle reaches and how fast it is going when it impacts the ground or water. Let us analyze what these mean:	
When an object reaches its maximum height, what is its velocity? _____	When an object hits the ground, what is its final position? _____
So to find the maximum height of an object, set $v(t) = 0$, solve for t , and find $s(t)$	So, to find the velocity of an object when it hits the ground, set $s(t) = 0$, solve for t , and find $v(t)$

Example 5) A projectile is launched vertically upward from ground level with an initial velocity of 112 ft/sec.

- a. Find the velocity and speed at $t = 3$ and $t = 5$ seconds.
- b. How high will the projectile rise?
- c. Find the speed of the projectile when it hits the ground.

Example 5) The equations for free fall at the surfaces of Mars, Earth, and Jupiter (s in meters, t in seconds) are:
Mars: $s(t) = 1.86t^2$, Earth: $s(t) = 4.9t^2$, Jupiter: $s(t) = 11.44t^2$. How long would it take a rock, initially at rest in a space capsule over the planet, to reach a velocity of 16.6 m/sec?

Mars

Earth

Jupiter

Example 6) A rock thrown vertically upward from the surface of the moon at a velocity of 24m/sec reaches a height of $s = 24t - 0.8t^2$ meters in t seconds.

- a) Find the rock's velocity and acceleration as a function of time. (The acceleration in this case is the acceleration on the moon)
- b) How long did it take the rock to reach its highest point?
- c) How high did the rock go?
- d) How long did it take the rock to reach half its maximum height?
- e) How long was the rock aloft?
- e) Find the rock's speed when hitting the moon.

Example 7) A ball is dropped from the top of the Washington Monument which is 555 feet high.

- a) How long will it take for the ball to hit the ground?
- b) Find the ball's speed at impact.

Example 8) Paul has bought a ticket on a special roller coaster at an amusement park which moves in a straight line. The position $s(t)$ of the car in feet after t seconds is given by: $s(t) = -.01t^3 + 1.2t^2$, $0 \leq t \leq 120$

- a) Find the velocity and acceleration of the roller coaster after t seconds?
- b) When is the roller coaster stopped?
- c) When is Paul speeding up and slowing down?
- d) Where is Paul at critical times of his ride?

Straight Line Motion - Homework

A particle is moving along a horizontal line with position function as given. Do an analysis of the particle's direction, acceleration, motion (speeding up or slowing down), and position.

1. $s(t) = 2 + 6t - t^2$

2. $s(t) = t^3 - 6t^2 + 9t - 4$

3. $s(t) = -t^3 + 9t^2 - 24t + 1$

4. $s(t) = t + \frac{9}{t+1} + 1$

5. A 45-caliber bullet fired straight up from the surface of the moon would reach a height of $s = 832t - 2.6t^2$ feet after t seconds. On Earth, in the absence of air, its height would be $s = 832t - 16t^2$ feet after t seconds. How long would it take the bullet to hit the ground in either case?

Earth

Moon

6. A ball fired downward from a height of 112 feet hits the ground in 2 seconds. Find its initial velocity.
7. A projectile is fired vertically upward (earth) from ground level with an initial velocity of 16 ft/sec.
- a. How long will it take for the projectile to hit the ground? b. How high will the projectile get?
8. A helicopter pilot drops a package when the helicopter is 200 ft. above the ground, rising at 20 ft/sec.
- a. How long will it take for the package to hit the ground? b. What is the speed of the package at impact?
9. A man drops a quarter from a bridge. How high is the bridge if the quarter hits the water 4 seconds later?
10. A projectile fired upward from ground level is to reach a maximum height of 1,600 feet. What is its initial velocity?

11. A projectile is fired vertically upward with an initial velocity of 96 ft/sec from a tower 256 feet high.
- How long will it take for the projectile to reach its maximum height.
 - What is its maximum height?
 - How long will it take the projectile to reach its starting position on the way down?
 - What is the velocity when it passes the starting point on the way down?
 - How long will it take to hit the ground?
 - What will be its speed when it impacts the ground?
12. John's car runs out of gas as it goes up a hill. The car rolls to a stop then starts rolling backwards. As it rolls, its displacement $d(t)$ in feet from the bottom of the hill at t seconds since the car ran out of gas is given by:
- $$d(t) = 125 + 31t - t^2.$$
- When is his velocity positive? What does this mean in real world terms?
 - When did the car start to roll backwards? How far was it from the bottom of the hill at that time?
 - If John keeps his foot off the brake, when will he be at the bottom of the hill?
 - How far was John from the bottom of the hill when he ran out of gas?
13. Ray is a sky-diver. When he free-falls, his downward velocity $v(t)$ feet per second is a function of t seconds from the time of the jump is given by: $v(t) = 251(1 - 0.88^t)$ measured in ft/sec.. Plot $v(t)$ and $a(t)$ on your calculator for the first 30 seconds of his dive.
- What is Ray's acceleration when he first jumps? Why does the acceleration decrease over time?
 - What appears to be the terminal velocity, $\lim_{t \rightarrow \infty} v(t)$?

Rolle's and the Mean Value Theorem - Classwork

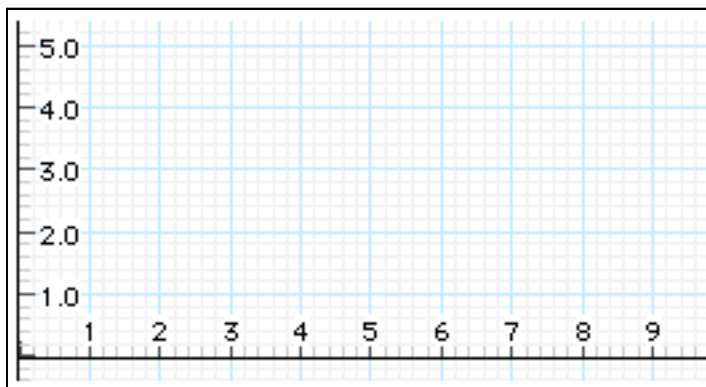

On the graph to the left, plot a point at $(2, 2)$ and another point at $(7, 2)$. Now draw 3 graphs of a differentiable function that starts at $(2, 2)$ and ends at $(7, 2)$. Is it possible that there is at least one point on your graphs for which the derivative is not zero? Is it possible that you can draw a graph for which there is not one point where the derivative is not zero?

Rolle's Theorem

Let f be continuous on the closed interval $[a, b]$ and differentiable on the open interval (a, b) . If $f(a) = f(b)$, then there is at least one number c in (a, b) such that $f'(c) = 0$.

What Rolle's theorem is that on a differentiable curve between two values of the same height, there must be at least one point in between where the tangent line is horizontal. In layman's terms, "what goes up must come down and what goes down must come back up."

Example 1) Show that Rolle's theorem holds between the intercepts of $f(x) = x^2 - 5x + 6$.

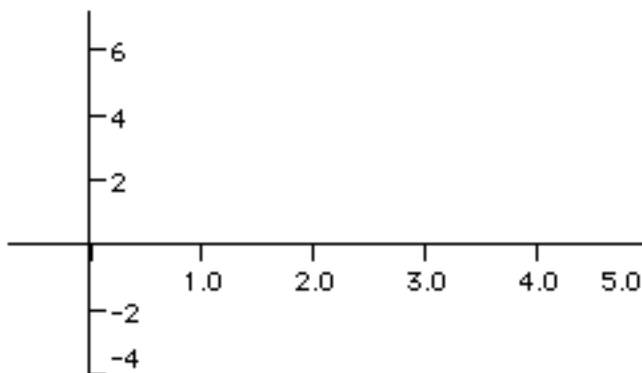

First of all, sketch

$$f(x) = x^2 - 5x + 6$$

What are the x -intercepts of $f(x) = x^2 - 5x + 6$? _____

Is the curve continuous? _____ Is the curve differentiable? _____ Why? _____

So you may now use Rolle's theorem. Do so.

Example 2) Find all values between the x -intercepts for which Rolle's theorem holds for the roots of $f(x) = 3x^2 - x^4$. Confirm using your calculator.

You are driving in a car traveling at 50 mph and you pass a police car. Four minutes later, you pass a second police car and you are traveling at 50 mph. The distance between the two police cars is five miles. The second police car nails you for speeding. How can he prove that you were speeding?

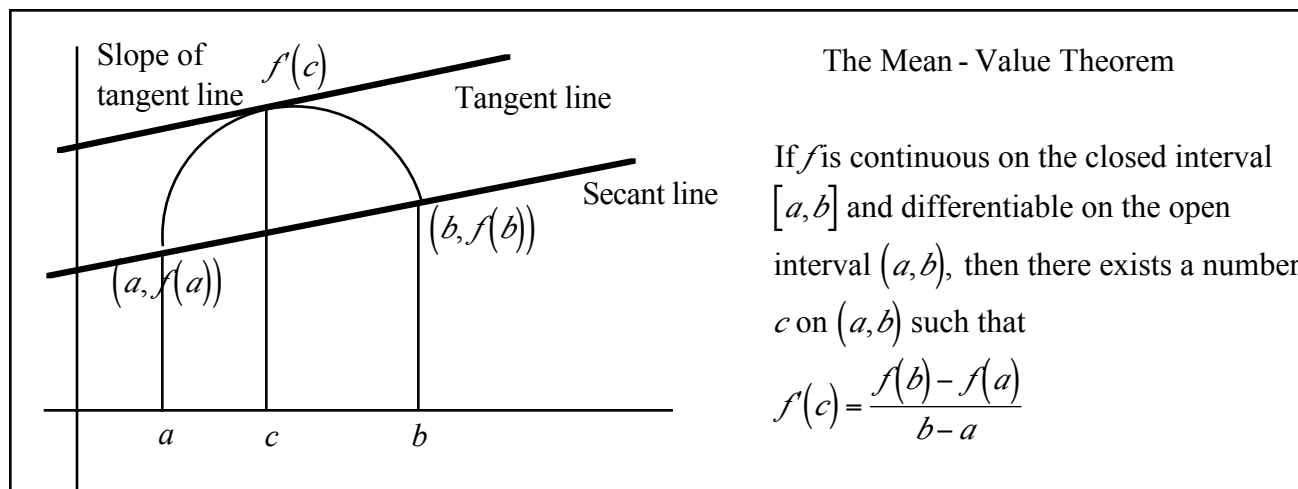

Example 3) Given $f(x) = 3 - \frac{5}{x}$. Find the value of c in the interval $(1, 5)$ that satisfies the mean value theorem.



Let's use the mean value theorem to find the solution.

To the left, is the graph of the function.

Visually, what is the mean value theorem trying to find? Draw it in.

Example 4) Find the equation of the tangent line to the graph of $f(x) = 2x + \sin x + 1$ on $(0, \pi)$ at the point which is the solution of the mean-value theorem. Confirm by calculator.

Example 5) Why can't you use the mean-value theorem for $f(x) = x^{2/3}$ on $(-1, 1)$?

Rolle's and the Mean Value Theorem - Homework

For the exercises below, determine whether Rolle's theorem can be applied to the function in the indicated interval. If Rolle's Theorem can be applied, find all values of x that satisfy Rolle's Theorem.

1. $f(x) = x^2 - 4x$ on $[0,4]$

2. $f(x) = x^2 - 11x + 30$ on $[5,6]$

3. $f(x) = (x-2)(x-3)(x-4)$ on $[2,4]$

4. $f(x) = (x+4)^2(x-3)$ on $[-4,3]$

5. $f(x) = 4 - |x-2|$ on $[-3,7]$

6. $f(x) = \sin x$ on $[0,2\pi]$

7. $f(x) = \cos 2x$ on $\left[\frac{\pi}{3}, \frac{2\pi}{3}\right]$

8. $f(x) = \frac{6x}{\pi} - 4 \sin^2 x$ on $\left[0, \frac{\pi}{6}\right]$

For the exercises below, apply the mean value theorem to $f(x)$ on the indicated interval. Find all values of c which satisfy the mean value theorem.

9. $f(x) = x^2$ on $[-1,2]$

10. $f(x) = x^3 - x^2 - 2x$ on $[-1,1]$

11. $f(x) = \frac{x+2}{x}$ on $\left[\frac{1}{2}, 2\right]$

12. $f(x) = \sqrt{x-3}$ on $[3, 7]$

13. $f(x) = x^3$ on $[0, 1]$

14. $f(x) = 2\cos x + \cos 2x$ on $[0, \pi]$

15. A trucker handed in a ticket at a toll booth showing that in 2 hours the truck had covered 159 miles on a toll road in which the speed limit was 65 mph. The trucker was cited for speeding. Why?

16. A marathoner ran the 26.2 mile New York marathon in 2 hours, 12 minutes. Show that at least twice, the marathoner was running at exactly 11 mph.

17. The order and transportation cost C of bottles of Pepsi is approximated by the function:

$$C(x) = 10,000\left(\frac{1}{x} + \frac{x}{x+3}\right) \text{ where } x \text{ is the order size of bottles of Pepsi in hundreds.}$$

According to Rolles's Theorem, the rate of change of cost must be zero for some order size in the interval $[3, 6]$. Find that order size.

18. A car company introduces a new car for which the number of cars sold S is the function:

$$S(t) = 300\left(5 - \frac{9}{t+2}\right) \text{ where } t \text{ is the time in months.}$$

a) Find the average rate of cars sold over the first 12 months.

b) During what month does the average rate of cars sold equal the rate of change of cars sales?

Function Analysis - Classwork

We now turn to analyzing functions via calculus. We did so in precalculus by determining the zeros of the function (where it crosses the x -axis) and the sign of the function between zeros. That gave us some information about the function but little clue as to its actual shape. Calculus will provide the missing pieces to the puzzle.

We will define a function as increasing if, as x moves to the right, the y -value goes up. A function is decreasing if, as x moves to the right, the y -value goes down. A function is constant if, as x moves to the right, the y -value doesn't change.

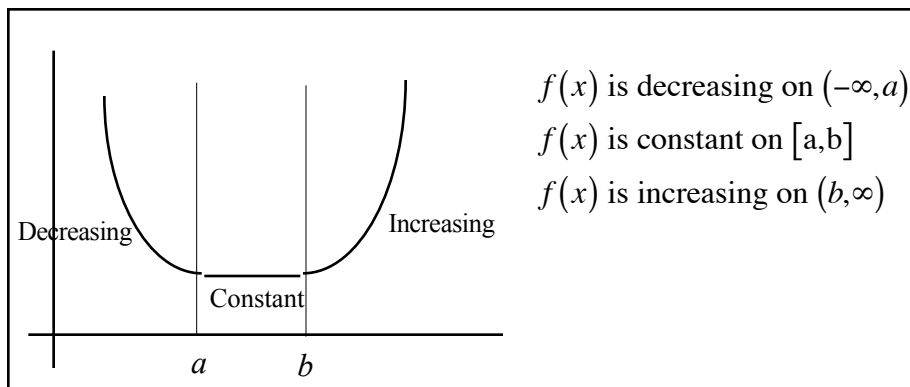

Increasing curves come in 3 varieties as shown. In each case, let's draw tangent lines at points along the curve.

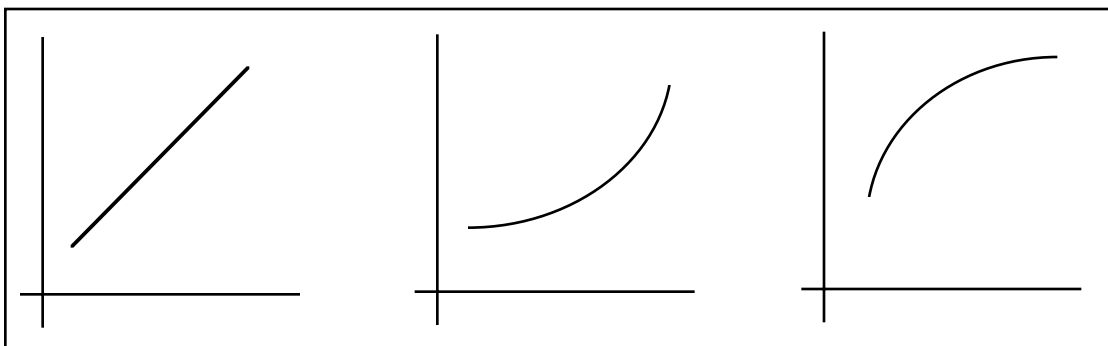

What is true about the slope of the tangent lines (i.e. the derivative) at all of these points? _____

Decreasing curves come in 3 varieties as shown. In each case, let's draw tangent lines at points along the curve.

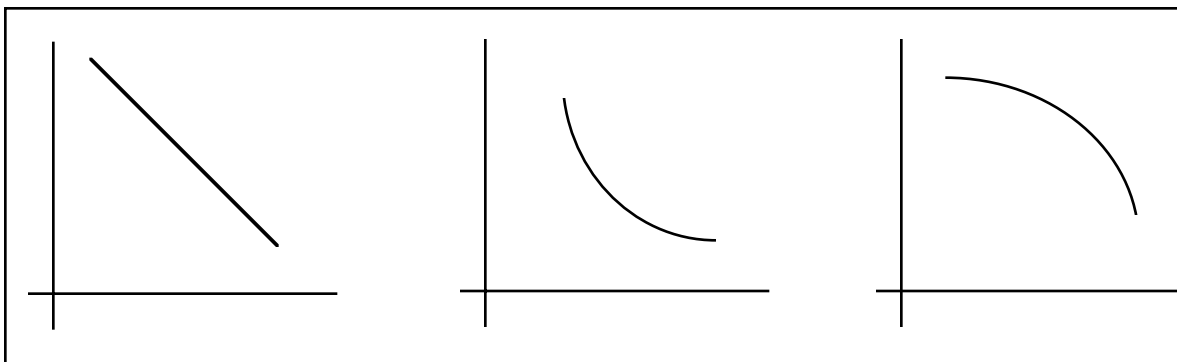

What is true about the slope of the tangent lines (i.e. the derivative) at all of these points? _____

So we can make the following statements about increasing and decreasing functions: Let f be a function that is continuous on the closed interval $[a,b]$ and differentiable on the open interval (a,b) ,

If $f'(x) > 0$ for all x in (a,b) , then f is increasing on $[a,b]$.
 If $f'(x) < 0$ for all x in (a,b) , then f is decreasing on $[a,b]$.
 If $f'(x) = 0$ for all x in (a,b) , then f is constant on $[a,b]$.

When we examine functions that have curves to them, we will define their curvature in terms of concavity. Concavity comes in two flavors - concave up and concave down.

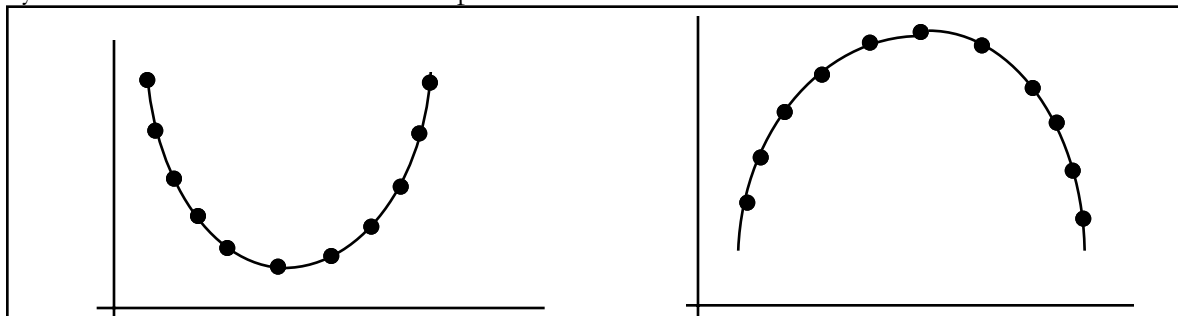

We call this curve **concave up**. The term I use is “holds water.” If water is poured into this structure, it will collect and “hold.”

On the concave up curve, draw tangent lines at the points shown. What is true about the slopes of these lines as you go left to right.

We call this curve **concave down**. The term I use is “spills water.” If water is poured into this structure, it will spill off.

On the concave down curve, draw tangent lines at the points shown. What is true about the slopes of these lines as you go left to right.

So we can define concavity as follows: If f is differentiable on an interval I . The graph of f is concave up on I if f' is increasing on the interval and concave down on I if f' is decreasing on the interval.

When you think “slope of tangent line”, you think _____

When you think increasing, you think _____

When you think decreasing, you think _____

So we are talking derivatives of derivatives, which means _____. So concavity is related to the sign of the second derivative, $f''(x)$. If $f''(x) > 0$, for all x in an interval, then the graph of f is concave up on the interval. If $f''(x) < 0$ for all x in an interval, then the graph of f is concave down on the interval. Straight lines have no concavity (concavity = 0). That makes sense as a line has no curvature. All of this can be summarized: When you are given information about $f'(x)$ and $f''(x)$, you can determine the shape of $f(x)$.

	$f'(x) > 0$	$f'(x) < 0$	$f'(x) = 0$
$f''(x) > 0$	$f(x)$ increasing, concave up	$f(x)$ decreasing, concave up	relative minimum, concave up
$f''(x) < 0$	$f(x)$ increasing, concave down	$f(x)$ decreasing, concave down	relative maximum, concave down
$f''(x) = 0$	$f(x)$ increasing, inflection point	$f(x)$ decreasing, inflection point	$f(x)$ levels off possible inflection point

Here are some terms which you must know. They are basic to any calculus course.

Critical Values (points): x -values on the function where the function has a slope equal to zero or where the function is not differentiable. Visually, it is where there is a horizontal tangent line or a vertical tangent line.

Stationary Point: A point on the function where there is a horizontal tangent at the x -value.

Relative Minimum: Informal definition: the bottom of a hill. Relative minimums occur where the curves switches from decreasing to increasing. The x -value is **where** the relative minimum occurs. The y -value is **what** the relative minimum is.

Relative Maximum: Informal definition: the top of a hill. Relative maximums occur where the curve switches from increasing to decreasing. The x -value is **where** the relative maximum occurs. The y -value is **what** the relative maximum is.

Relative Extrema: Either a relative minimum or relative maximum.

Absolute maximum or minimum. The highest (lowest) point on the curve. The x -value is **where** the absolute maximum (minimum) occurs. The y -value is **what** the absolute maximum (minimum) is. The absolute minimum or maximum must occur at relative extrema or at the endpoints of an interval.

Inflection point: The x -value where the curve switches concavity. Inflection points can occur where the second derivative equals zero or fails to exist.

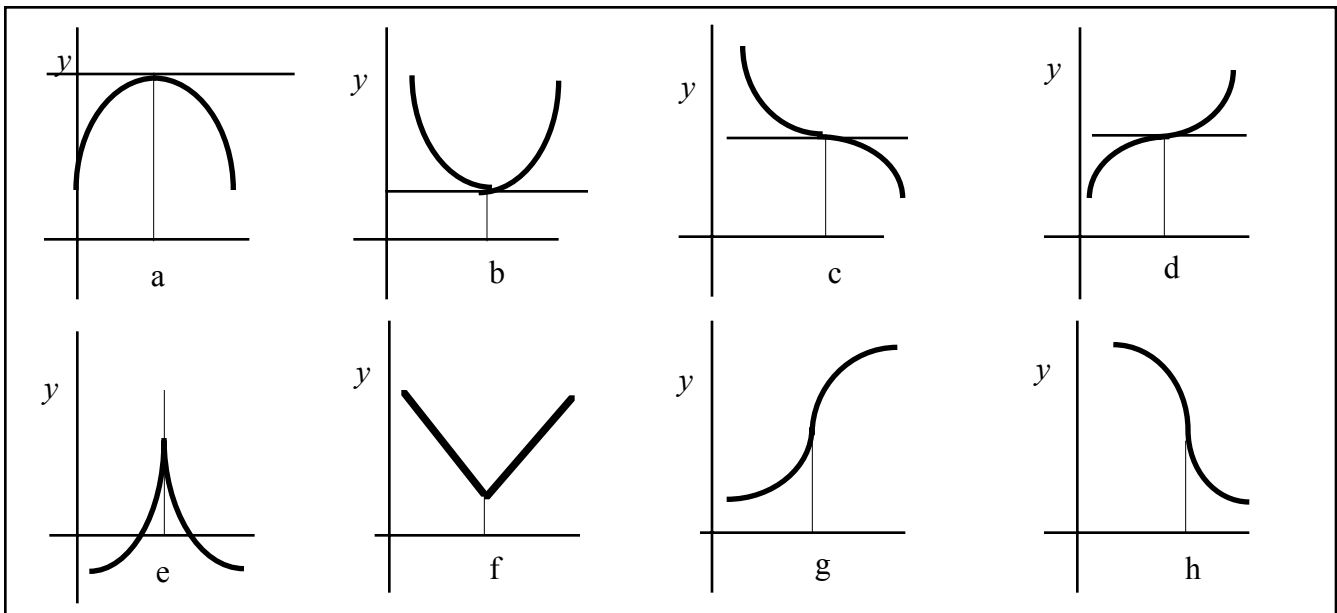

Example 1) For each term, determine if it is applicable at the x -values a - h.

	Critical Point	Relative Minimum	Relative Maximum	Stationary Point	Inflection Point
a					
b					
c					
d					
e					
f					
g					
h					

Example 2) You are given a graph of $f'(x)$. Draw a picture of a possible $f(x)$.

a. $f'(x)$ possible $f(x)$

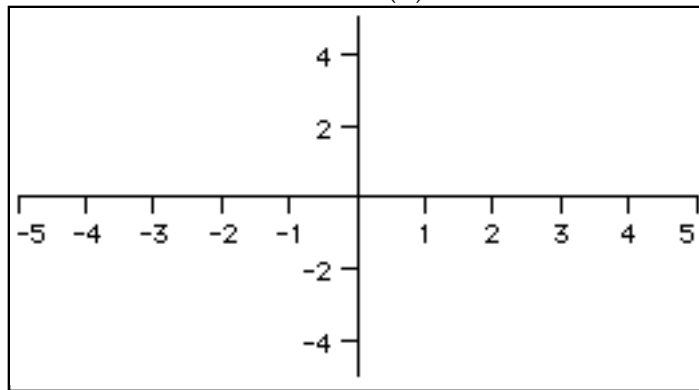
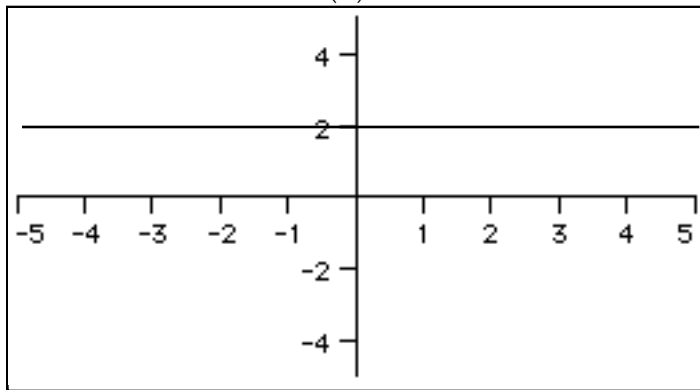

b. $f'(x)$ possible $f(x)$

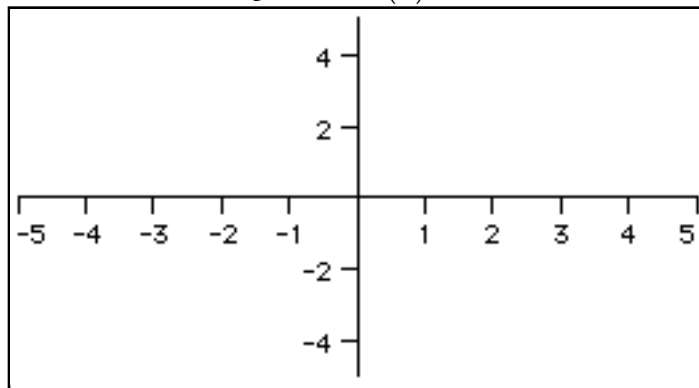
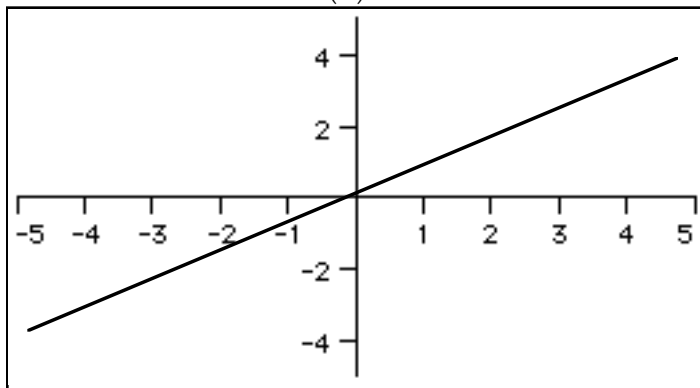

c. $f'(x)$ possible $f(x)$

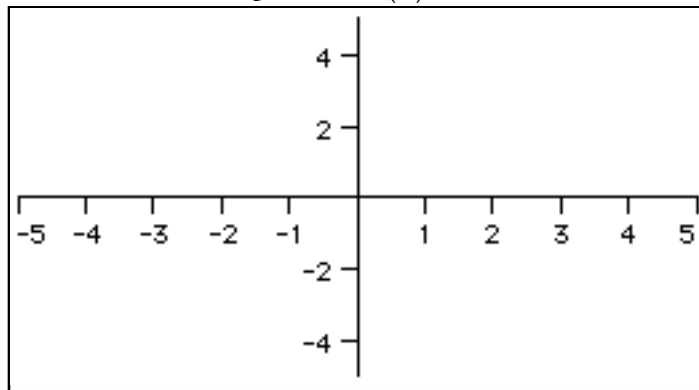
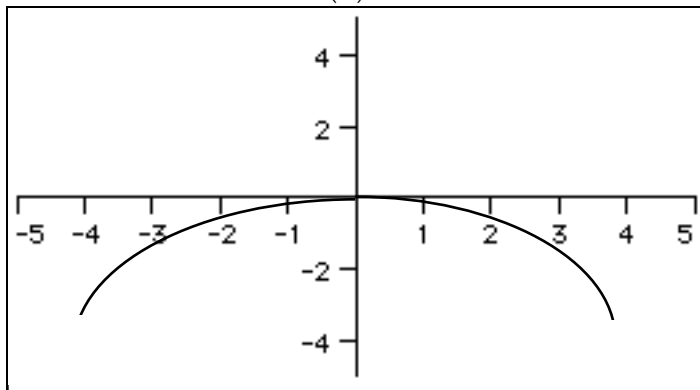

d. $f'(x)$ possible $f(x)$

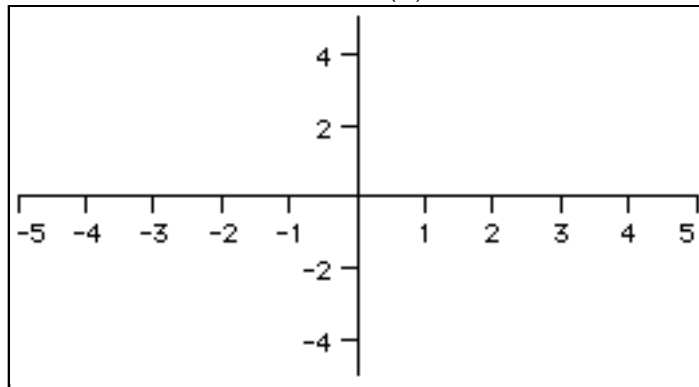
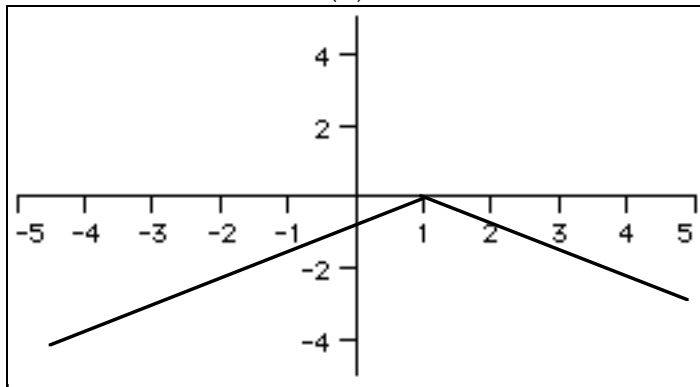

e.

$f'(x)$

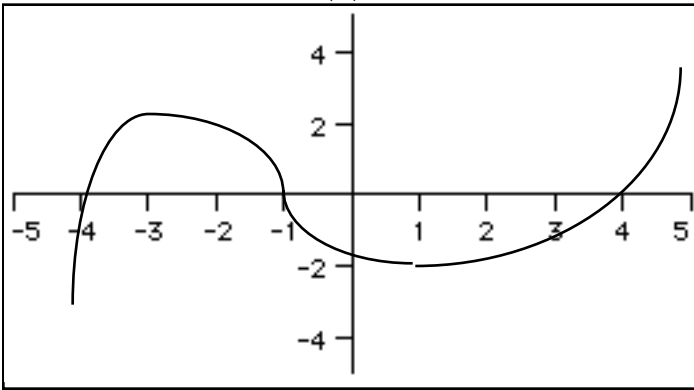

possible $f(x)$

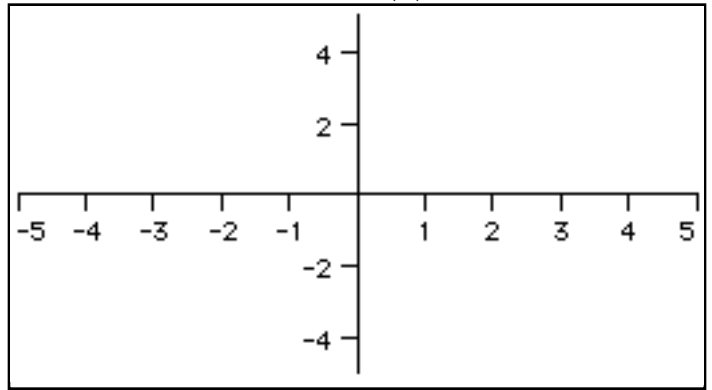

f.

$f'(x)$

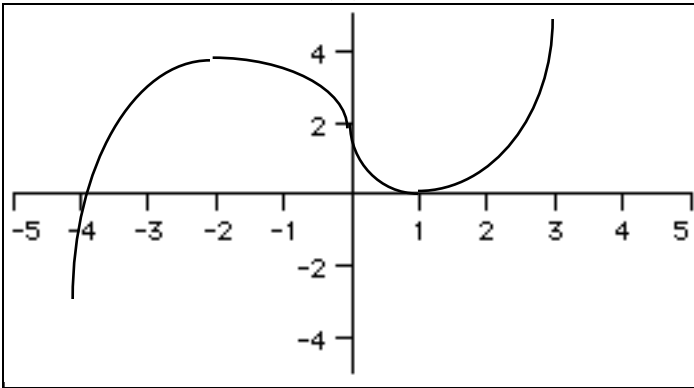

possible $f(x)$

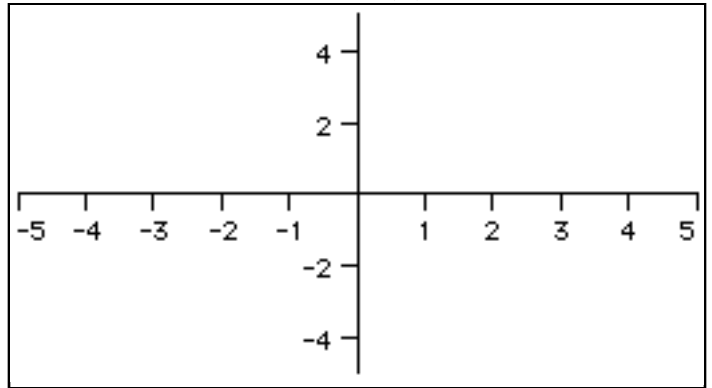

g.

$f'(x)$

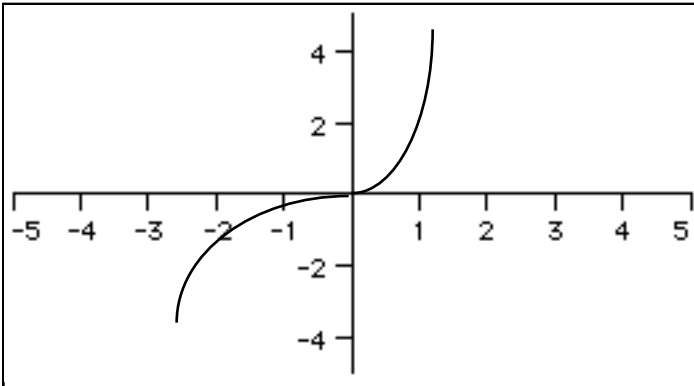

possible $f(x)$

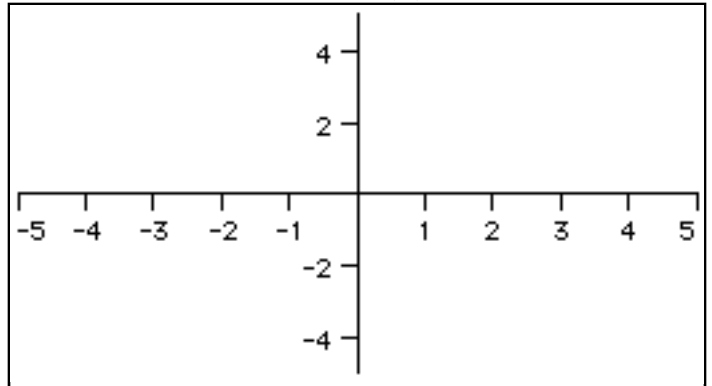

h.

$f'(x)$

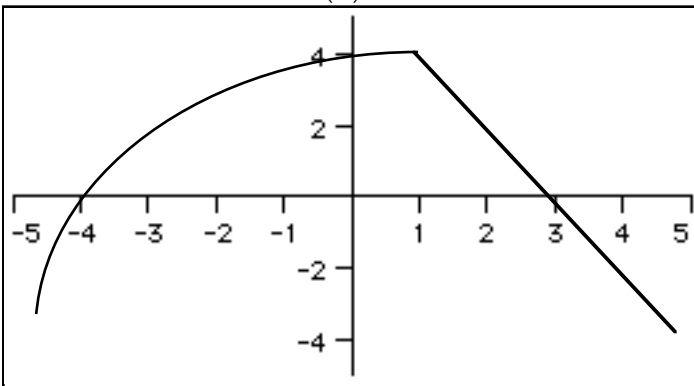

possible $f(x)$

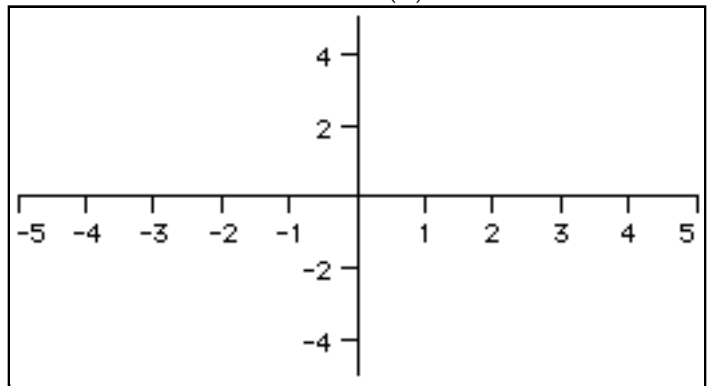

Example 3) You are given a graph of $f'(x)$. Draw a picture of a possible $f(x)$.

a. $f'(x)$ possible $f(x)$

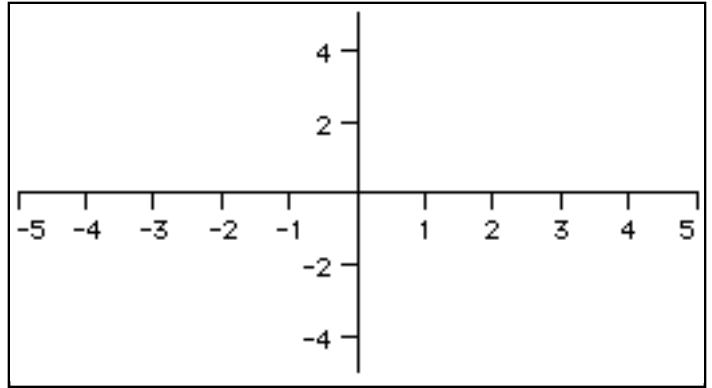
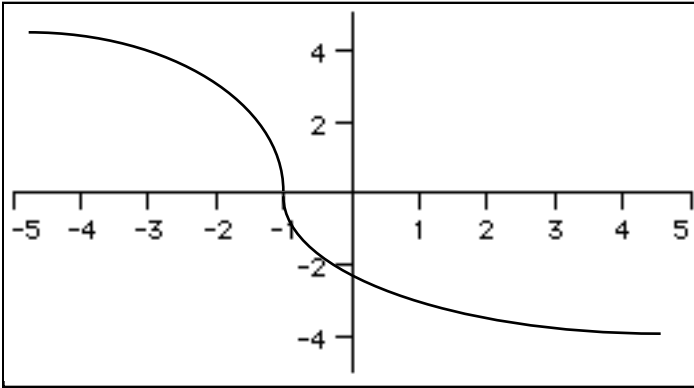

b. $f'(x)$ possible $f(x)$

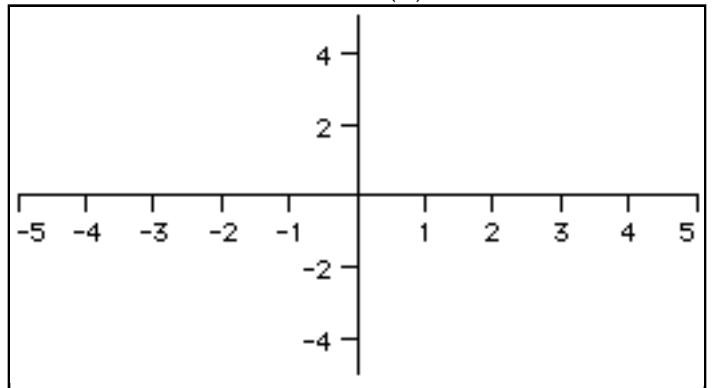
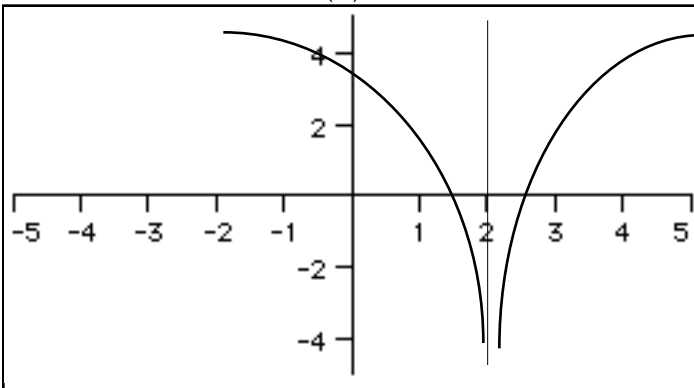

c. $f'(x)$ possible $f(x)$

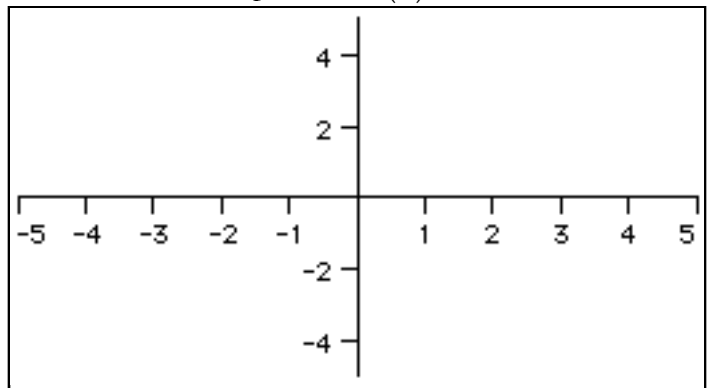
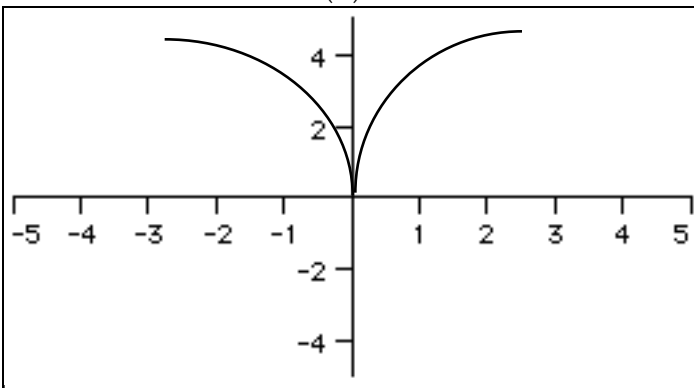

d. $f'(x)$ possible $f(x)$

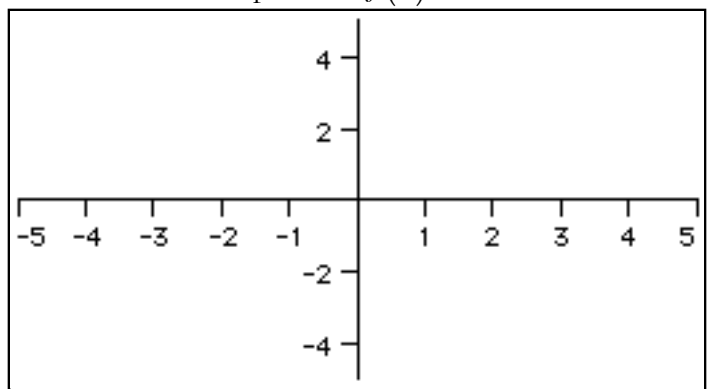
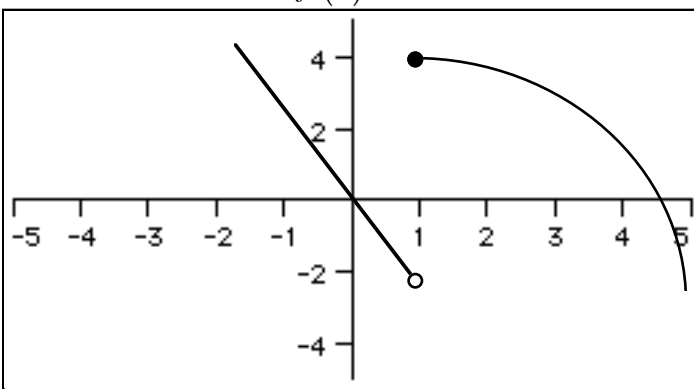

Example 4) Sketch a possible $f(x)$ given the following information.

a. $f'(x) > 0$
 $f''(x) > 0$.
 $f(1) = -2$

b. $f'(x) > 0, x > 1, f'(x) < 0, x < 1, f'(1) = 0$
 $f''(x) > 0, f(1) = -1$

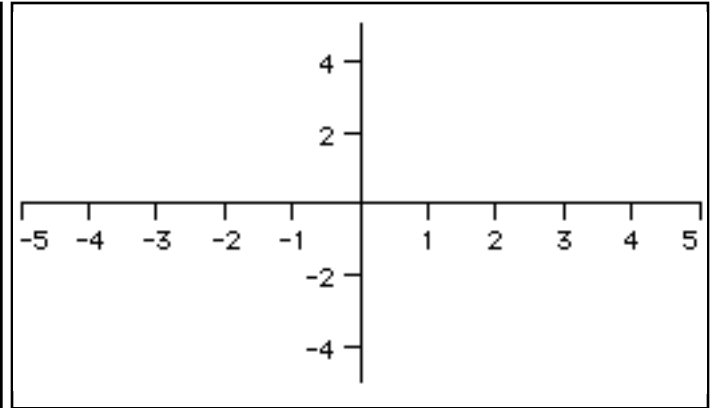
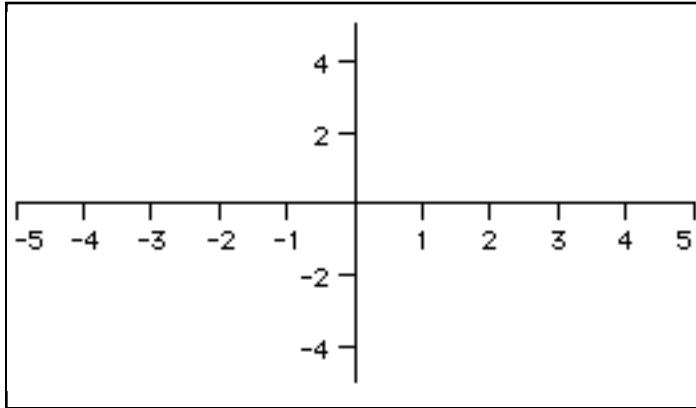

c. $f'(x) > 0, x > 2, f'(x) = 0, x \leq 2$
 $f''(x) > 0, x > 2, f(2) = 1$

d. $f'(x) > 0, x > -1, f'(x) < 0, x < -1$
 $f''(x) < 0, f(-1) = -4$

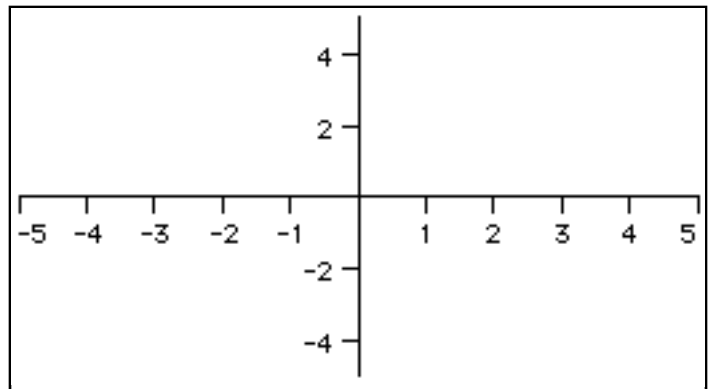
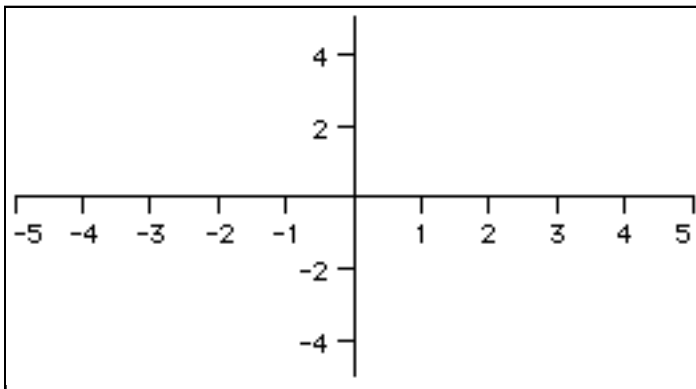

e. $f'(x) > 0, x > 1, f'(x) > 0, x < -3, f'(x) < 0, -3 < x < 1$
 $f'(-3) = 0, f'(1) = 0$
 $f''(x) < 0, x < 0, f''(x) > 0, x > 0$

f. $f'(x) > 0, x > 2, f'(x) = -1, x < 2, f'(2) \text{ DNE}$
 $f''(x) < 0, x > 2, f(2) = 0$

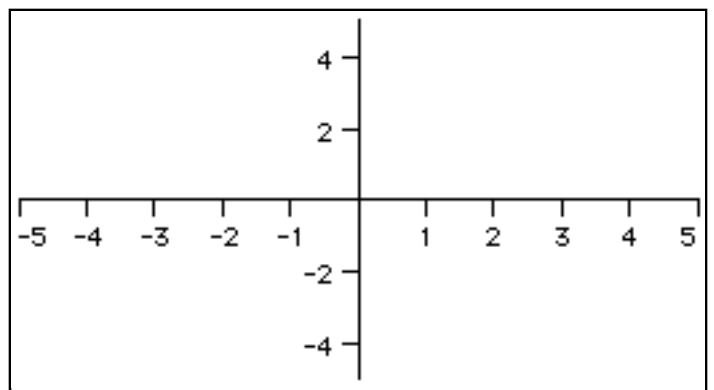
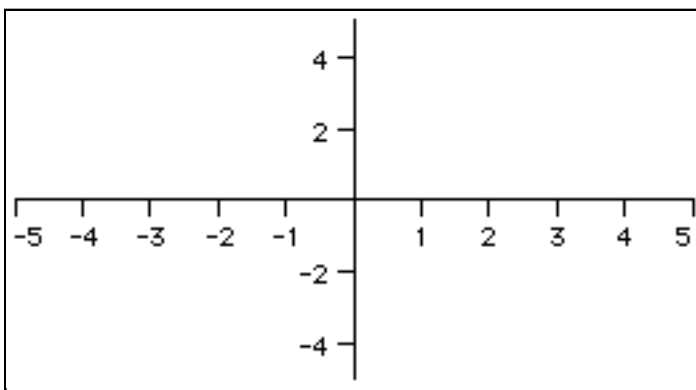

Now that we can determine the graph of a function by examining its first and second derivatives, we now attack the problem from algebraically. We wish to graph some function $f(x)$ by finding its relative maximum and minimum (extrema). With the advent of graphing calculators, a lot of this work is now done by technology and the act of sheer graphing of functions is being reduced on the A.P. exam.

To determine relative extrema of a function , do the following steps.

1. Find the derivative $f'(x)$. It is best that it be in a fraction form.
2. Find the critical values by setting $f'(x) = 0$ or by finding where $f'(x)$ is undefined. If $f'(x)$ is in fraction form, you merely set the numerator and denominator of $f'(x) = 0$ and solve.
3. Make a sign chart for $f'(x)$. Be sure you label it. On it, you will place every critical value c found above.
4. If the sign chart switches from positive to negative at a critical value, at c , it is a relative maximum. If the sign chart switches from negative to positive at a critical value, at c , it is a relative minimum.

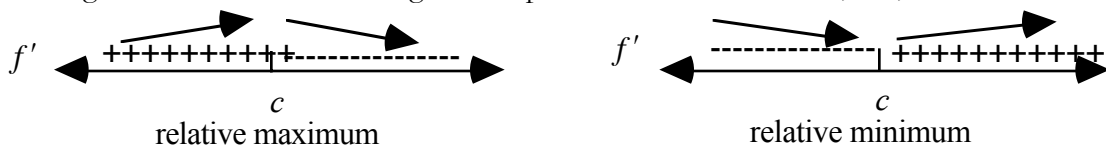

If there is no switch of signs at c , then c is not a relative minimum or maximum.

5. You have identified the x -values where extrema occur. If you are asked to find the **points** where relative maxima and minima occur, you must take every maximum and minimum value c found above and plug them into the function. That is, find $f(c)$.
6. Inflection points occur where the sign of the second derivative $f''(x)$ switches sign. Take the second derivative $f''(x)$, put in fraction form and find every value c where either the numerator or denominator of $f''(x)$ equals zero.
7. If the sign chart switches signs at c then an inflection point occurs at c . We don't care if $f''(c)$ exists.



If there is no switch of signs at c , then c is not a point of inflection.

8. You have identified the x -values where points of inflection occur. If you are asked to find the actual **point of inflection**, you must take every inflection point value c found above and plug it into the function. That is, find $f(c)$.

Example 5) Find all points of relative maximum and relative minimum and points of inflection if any. Justify your answers. Confirm by calculator.

a) $f(x) = x^3 - 3x^2$

b. $f(x) = 4x^3 - x^4$

c) $f(x) = 6x^5 - 10x^3$

d. $f(x) = -\cos x - \frac{1}{2}x$ on $[0, 2\pi]$

e. $f(x) = \frac{4}{x^2 + 4}$

Don't do inflection pts.

f. $f(x) = \frac{x^2 + 1}{x^2 - 9}$

Don't do inflection pts.

Example 6) An airplane starts its descent when it is at an altitude of 1 mile, 6 miles east of the airport runway.

Find the cubic function $f(x) = ax^3 + bx^2 + cx + d$ on the interval $[0, 6]$ that describes a smooth glide path for the plane. Also find the location where the plane is descending at the fastest rate.

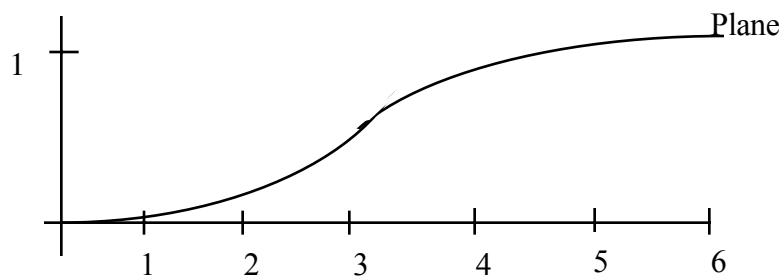

Function Analysis - Homework

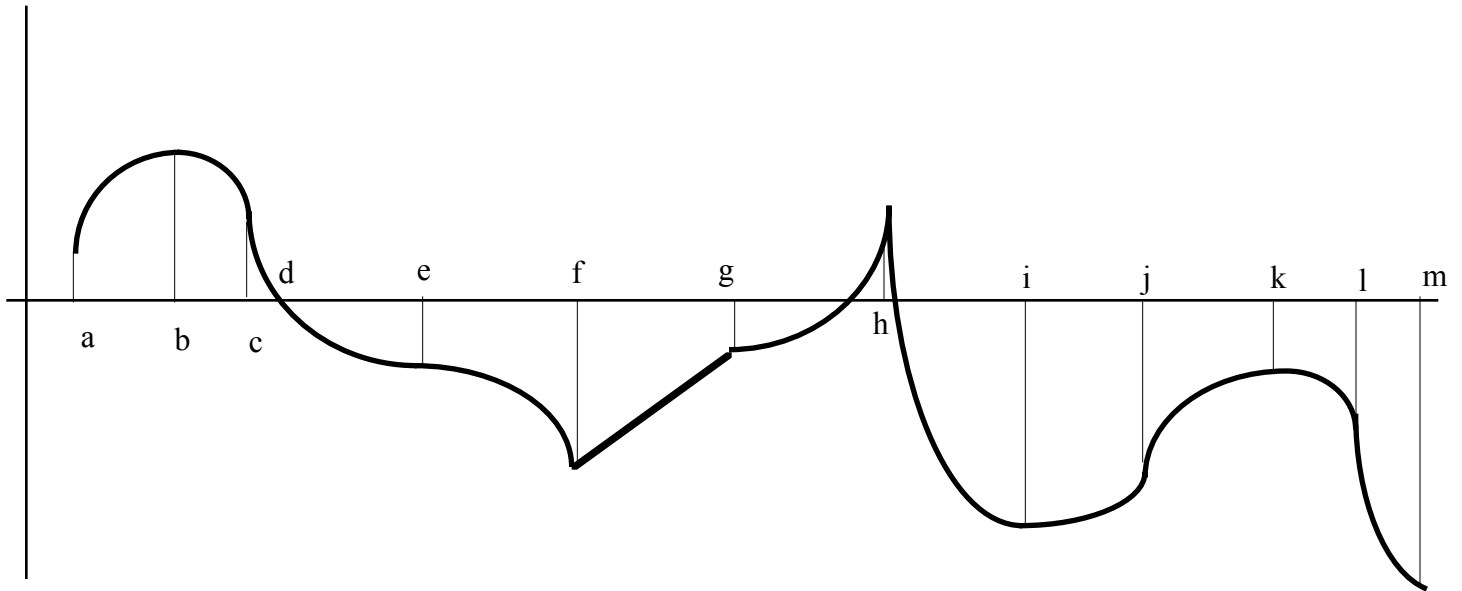

1. For each term, determine if it is applicable at the x -values a - m.

	Critical Point	Relative Minimum	Relative Maximum	Stationary Point	Inflection Point	Absolute Minimum	Absolute Maximum
a							
b							
c							
d							
e							
f							
g							
h							
i							
j							
k							
l							
m							

2) You are given a graph of $f'(x)$. Draw a picture of a possible $f(x)$.

a. $f'(x)$ possible $f(x)$

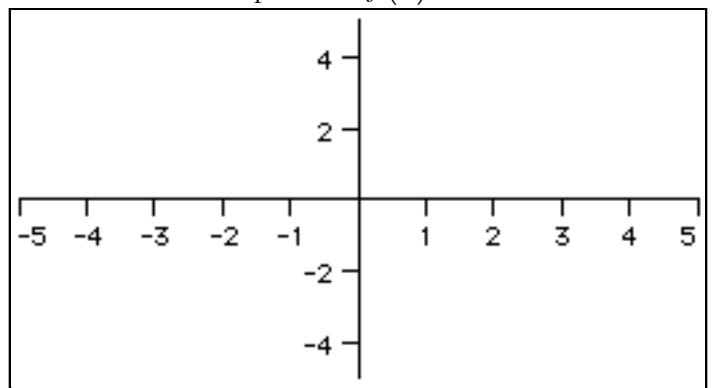
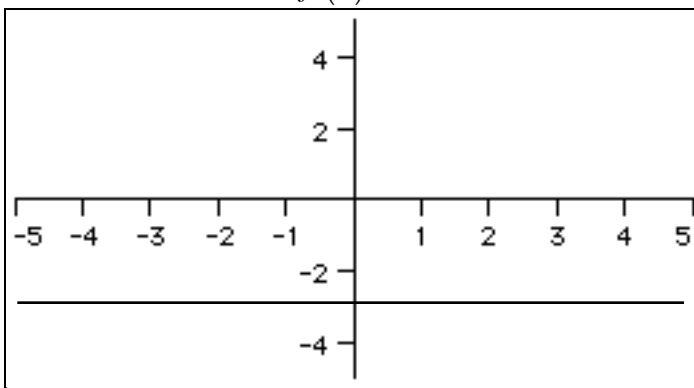

b. $f'(x)$ possible $f(x)$

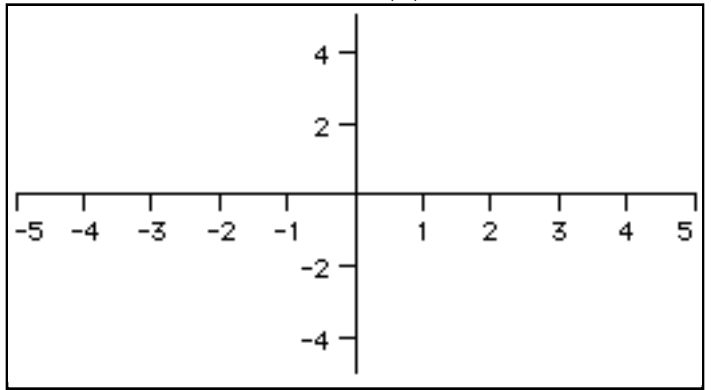
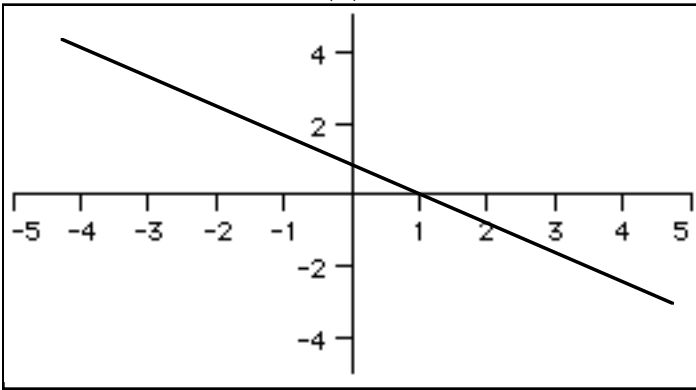

c. $f'(x)$ possible $f(x)$

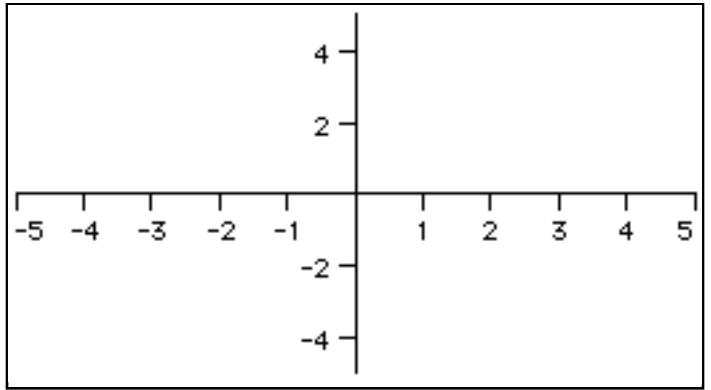
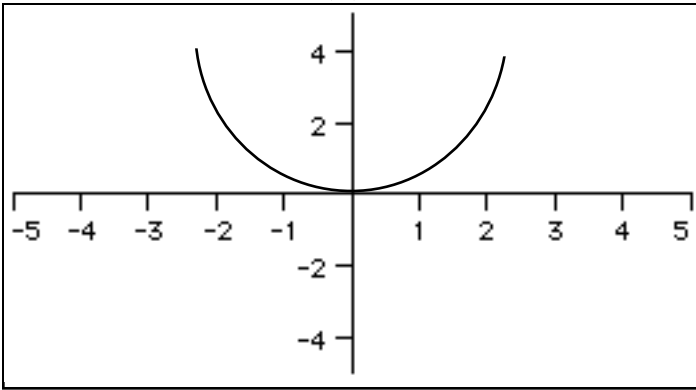

d. $f'(x)$ possible $f(x)$

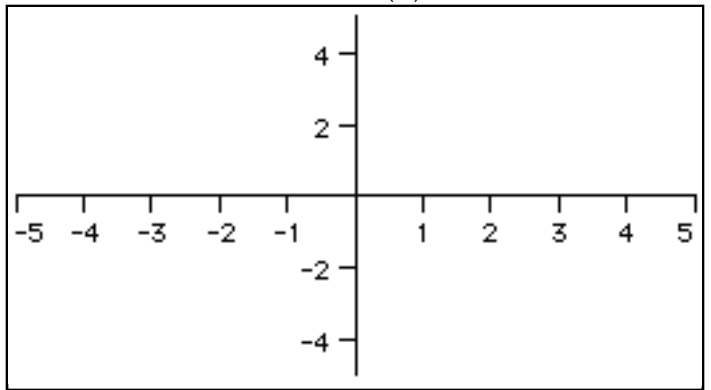
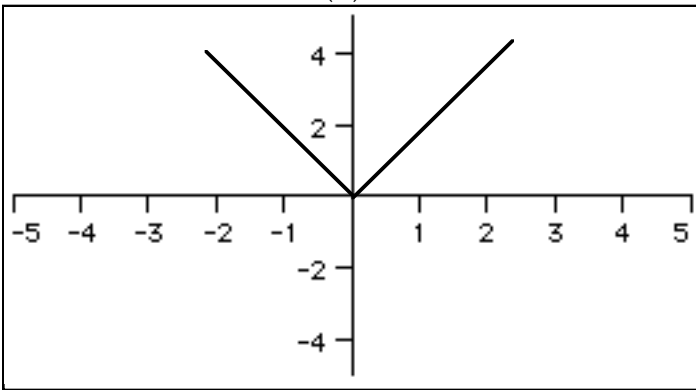

e. $f'(x)$ possible $f(x)$

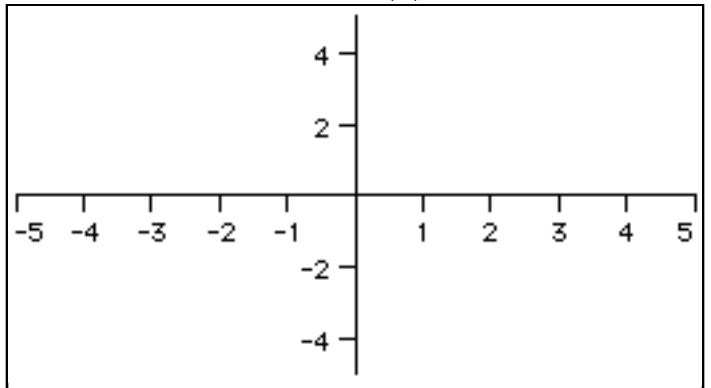
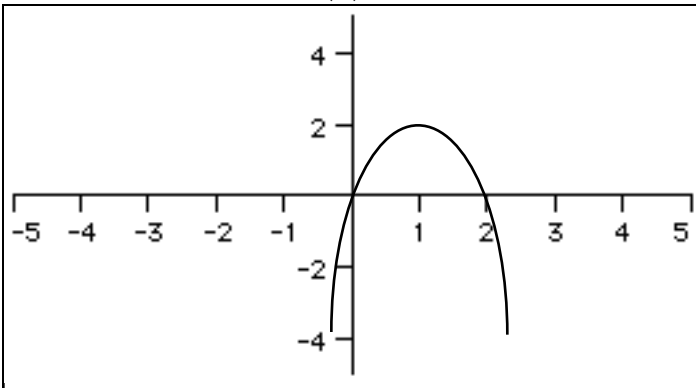

f.

$f'(x)$

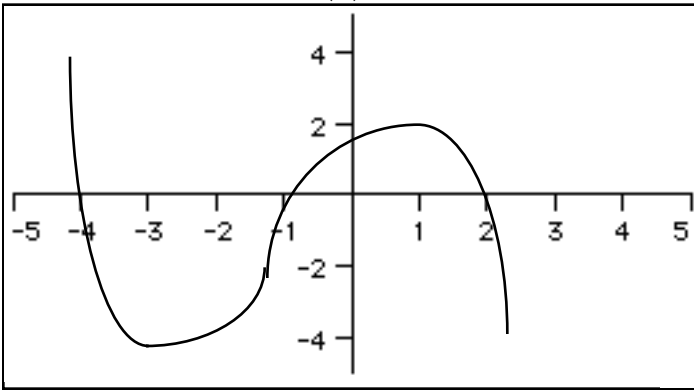

possible $f(x)$

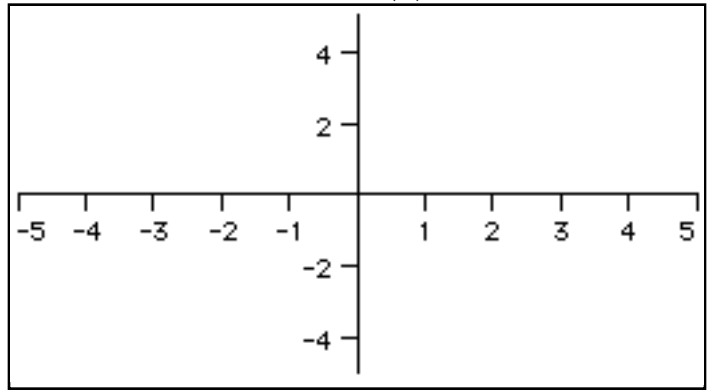

g.

$f'(x)$

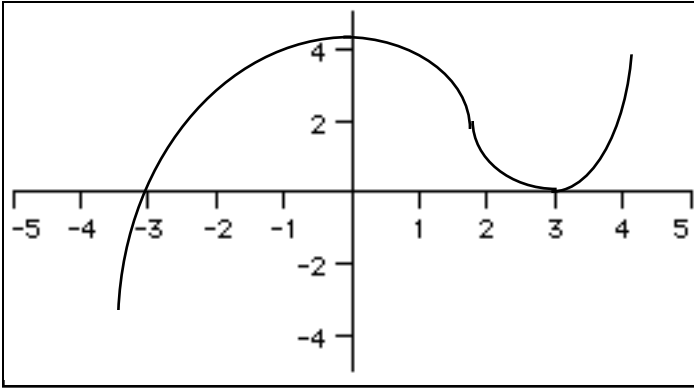

possible $f(x)$

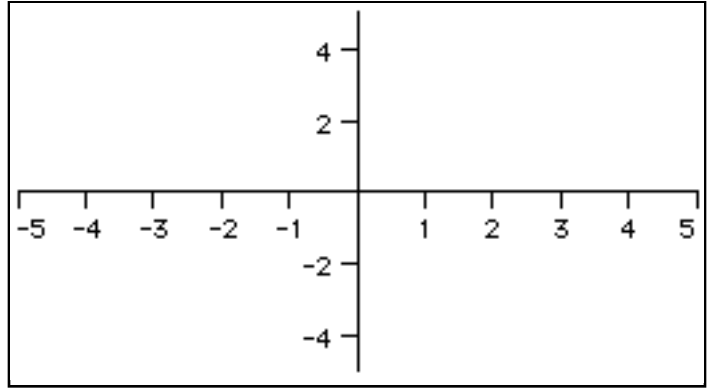

h.

$f'(x)$

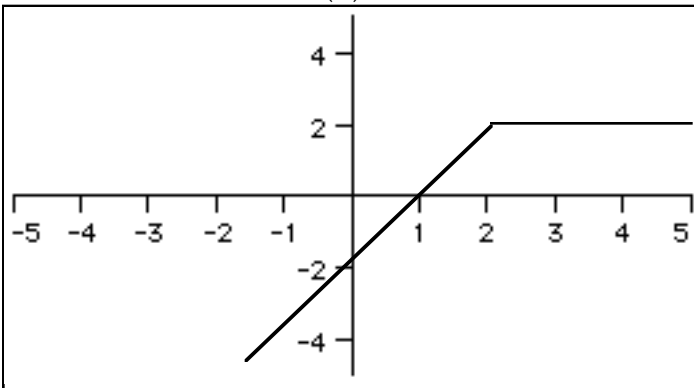

possible $f(x)$

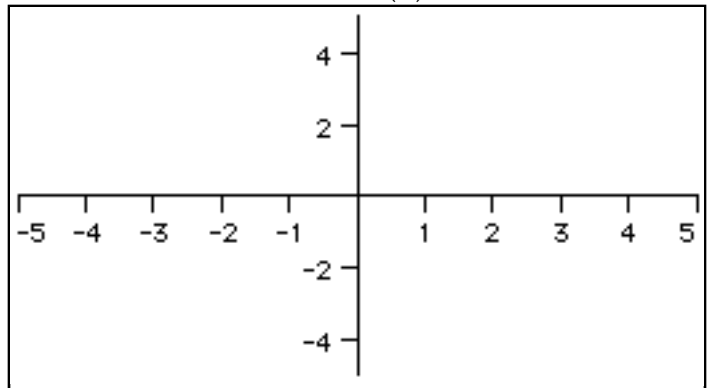

i.

$f'(x)$

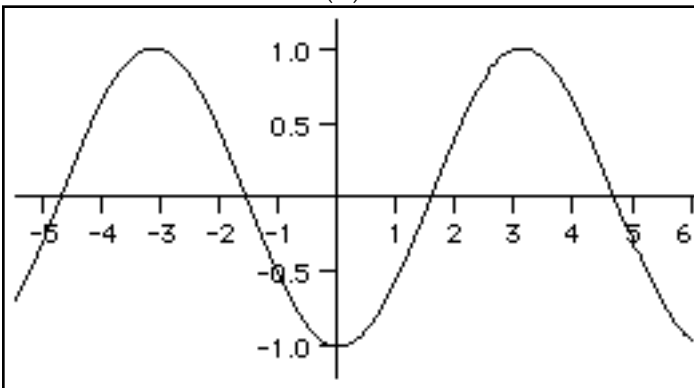

possible $f(x)$

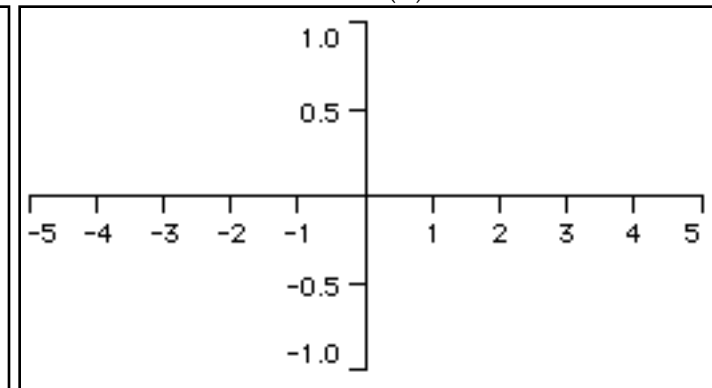

3) You are given a graph of $f'(x)$. Draw a picture of a possible $f(x)$.

a. $f'(x)$ possible $f(x)$

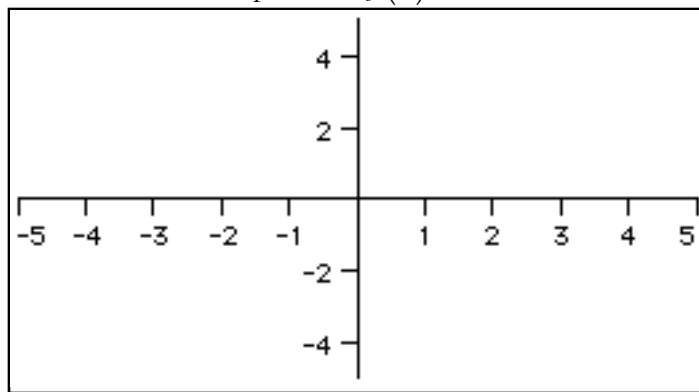
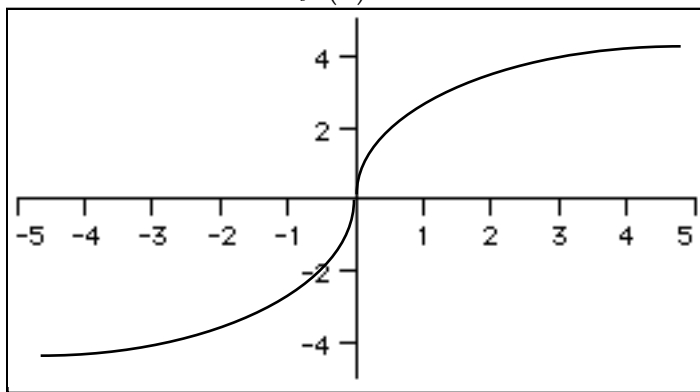

b. $f'(x)$ possible $f(x)$

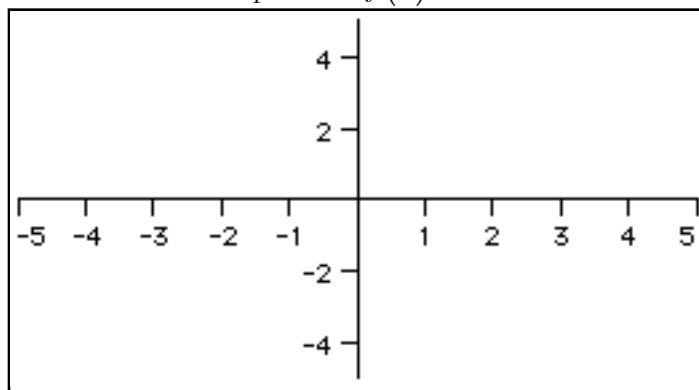
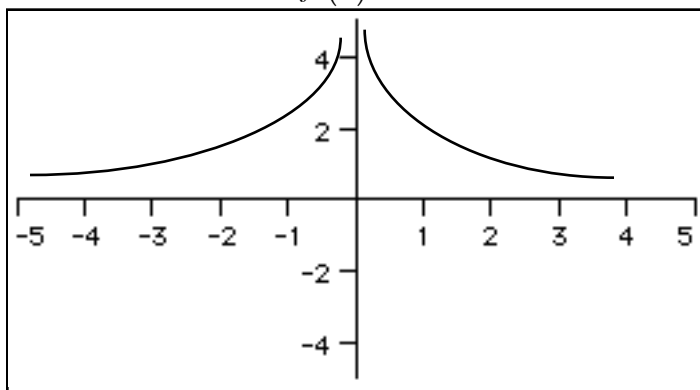

c. $f'(x)$ possible $f(x)$

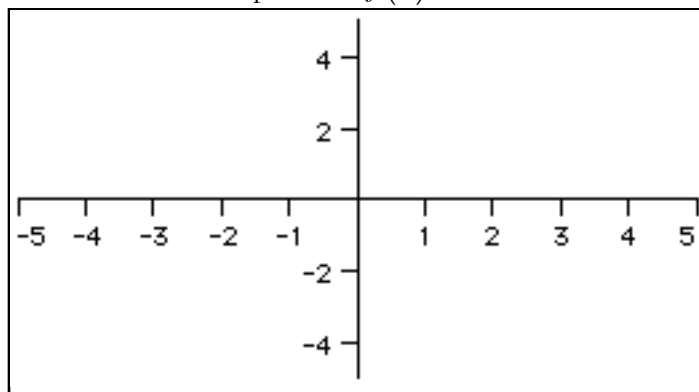
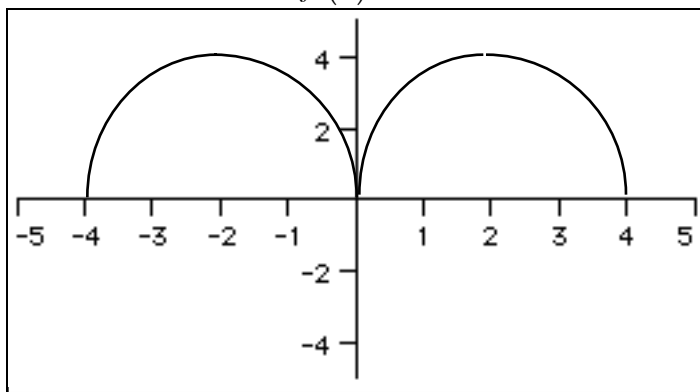

d. $f'(x)$ possible $f(x)$

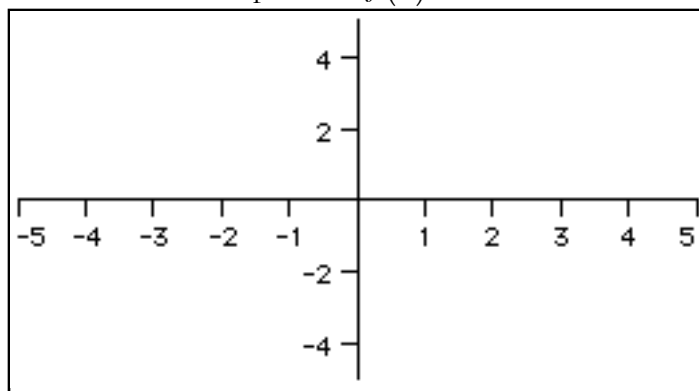
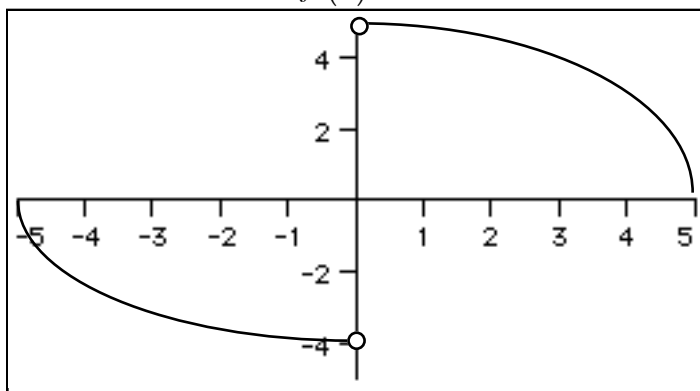

4) Sketch a possible $f(x)$ given the following information.

a. $f'(x) > 0, \quad f''(x) < 0$
 $f(0) = 2$

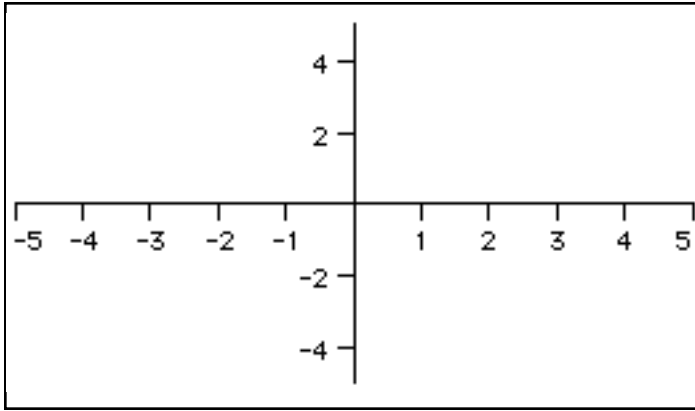

b. $f'(x) > 0, x > 1, \quad f'(x) = -1, x < 1$
 $f(1) = -1 \quad \lim_{x \rightarrow \infty} f(x) = 4$

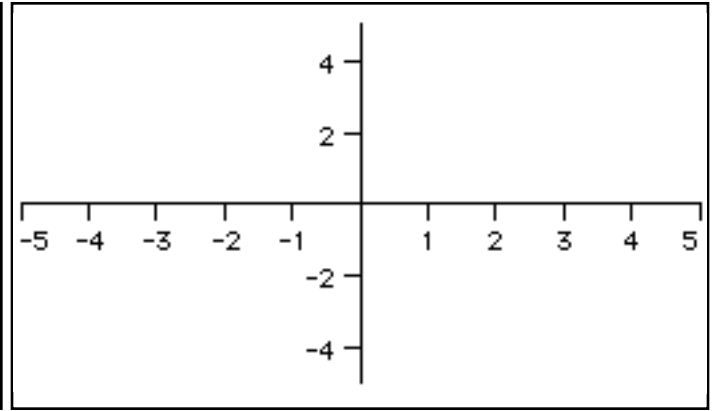

c. $f'(x) < 0, x < 2 \quad f''(x) > 0, x < 2$
 $f(x) = 1, x \geq 2 \quad y\text{-intercept} = 2$

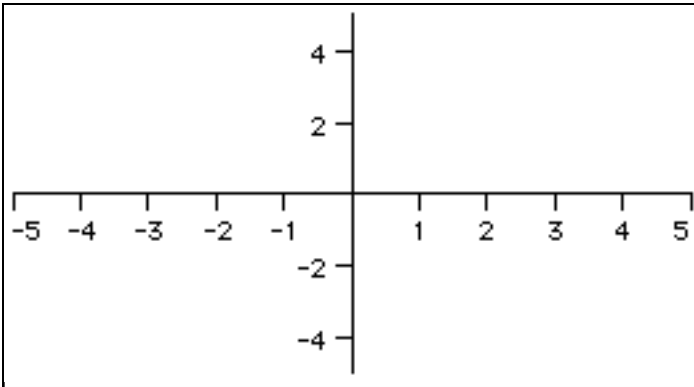

d. $f'(x) < 0, x < 0 \quad f'(x) > 0, x > 0$
 $f''(x) > 0 \quad f(0) = -1$

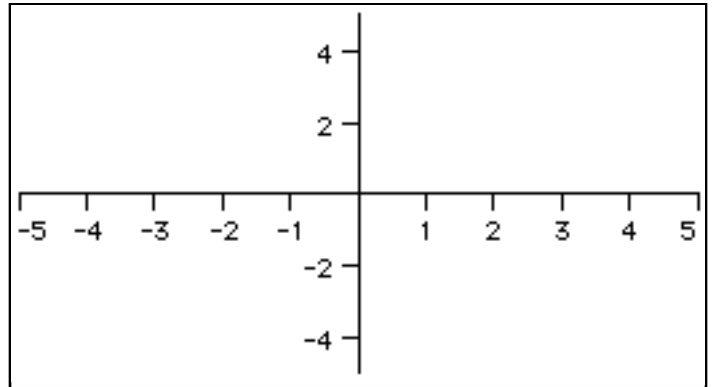

e. $f'(x) > 0 \quad f(0) = 0$
 $\lim_{x \rightarrow \infty} f(x) = 1 \quad \lim_{x \rightarrow -\infty} f(x) = -1$

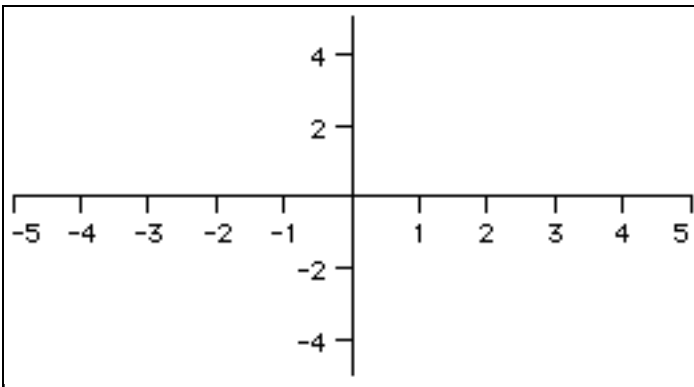

f. $f'(x) > 0, x < 0 \quad f'(x) > 0, x > 3 \quad f'(x) < 0, 0 < x < 3$
 $f(0) = 0 \quad f(0) = 3 \quad f(3) = 0$
 $f''(x) < 0, x < 3 \quad f''(x) > 0, x > 3$

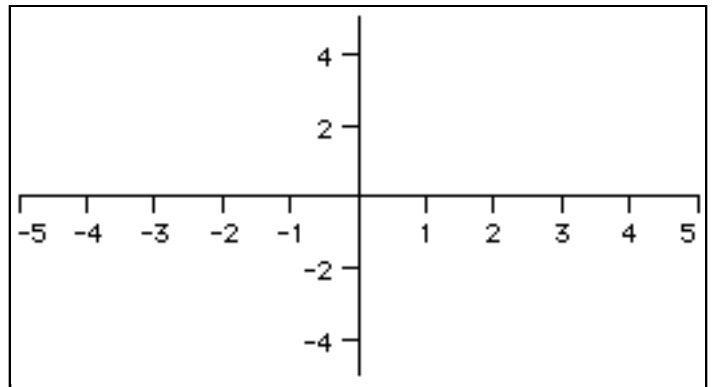

$$f'(x) < 0, x < 0 \quad f'(x) < 0, x > 3 \quad f'(x) > 0, 0 < x < 3 \quad f'(x) > 0, x \neq 0 \quad f'(0) = 0$$

$$g. \quad f'(0) = 0 \quad f(0) = -2 \quad f''(-2) = 0 \quad h. \quad f''(x) < 0, x < 0 \quad f''(x) > 0, x > 0$$

$$\lim_{x \rightarrow \pm\infty} f(x) = 0 \quad \lim_{x \rightarrow 3} f(x) = \infty \quad f(0) = 1$$

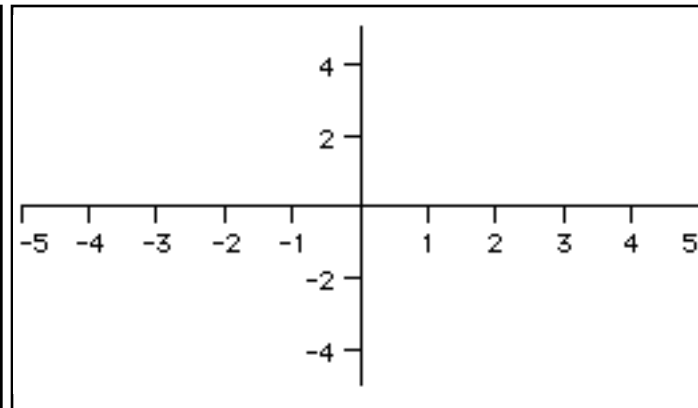
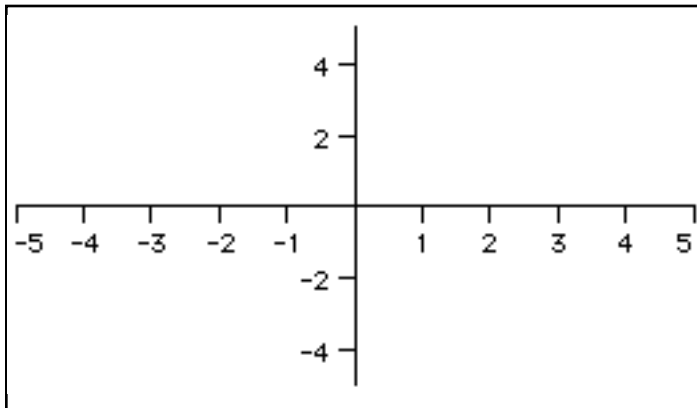

$$f'(x) > 0, x \neq 0 \quad f'(0) \text{ DNE}$$

$$i. \quad f''(x) > 0, x < 0 \quad f''(x) < 0, x > 0 \quad f(0) = 1$$

$$j. \quad f'(x) < 0, x > 0 \quad f''(x) < 0, x > 0$$

$$\lim_{x \rightarrow 0^+} f(x) = 4 \quad f \text{ is symmetric to the origin}$$

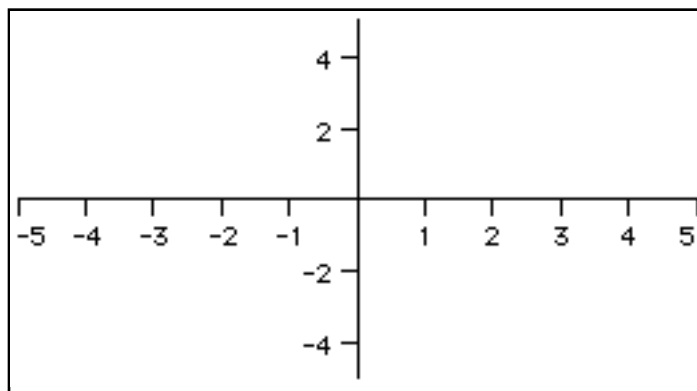
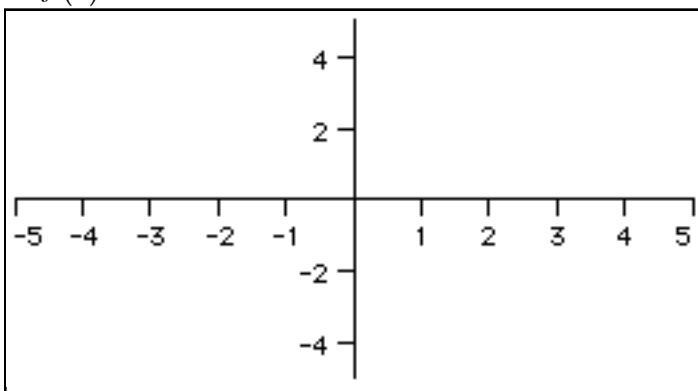

5) Find all points of relative maximum and relative minimum and points of inflection if any. Justify your answers. Confirm by calculator.

a. $f(x) = x^2 - 8x + 4$

b. $f(x) = 1 + 12x - 3x^2 - 2x^3$

c. $f(x) = (2x - 5)^3$

d. $f(x) = 3\sqrt[3]{x} - 2$

e. $f(x) = \frac{x^2}{x^2 - 4}$ (don't do inflection pts)

f. $f(x) = \sin^2 x + \sin x$ $[0, 2\pi]$
don't do inflection pts)

g. $f(x) = x - \cos x$ $[0, 2\pi]$

h. $f(x) = x\sqrt{x+1}$ (don't do inflection pts)

i. $f(x) = (x^2 - 16)^{2/3}$ (don't do inflection pts)

Finding Absolute Maximums and Minimums - Classwork

Suppose you were asked to find the student in this school who, at this point in time, has the most money on him or her. Write below a method that would be efficient and quick.

Our goal will be to find a maximum value of a function and minimum value of a function on a closed interval. Knowing that relative maxima and minima occur only at critical values (where the derivative equals zero or fails to exist), the method for finding absolute maxima and minima on a closed interval $[a,b]$ is as follows:

1. Find the critical value of f in (a,b) . (set both the numerator and denominator of $f' = 0$ and solve).
2. Evaluate f at each critical number in (a,b) .
3. Evaluate f at each endpoint of $[a,b]$ - that is find $f(a)$ and $f(b)$.
4. The smallest of these is the absolute minimum. The largest of these is the absolute maximum.
5. Remember to discern the difference between **where** the absolute min or max occurs as opposed to **what** the absolute min or max is. **Where** is the x -value. **What** is the y -value.

Examples) Find the absolute minimum and maximum values of the following functions. Justify your answers.

a. $f(x) = 3x^2 - 24x - 1$ $[-1,5]$

b. $f(x) = 6x^3 - 6x^4 + 5$ $[-1,2]$

c. $f(x) = 3x^{2/3} - 2x + 1$ $[-1,8]$

d. $f(x) = \sin^2 x + \cos x$ $[0,2\pi]$

Finding Absolute Maximums and Minimums - Homework

Find the absolute maximums and minimums of f on the given closed interval and state where these values occur.

1. $f(x) = 4x^2 - 4x + 1$ $[0, 2]$

2. $f(x) = 2x^3 - 3x^2 - 12x - 1$ $[-2, 3]$

3. $f(x) = \frac{x}{x^2 + 2}$ $[-1, 4]$

4. $f(x) = (x^2 - 2)^{\frac{2}{3}}$ $[-2, 3]$

5. $f(x) = x^{\frac{2}{3}}(20 - x)$ $[-1, 20]$

6. $f(x) = \sin x - \cos x$ $[0, \pi]$

7. $f(x) = x - \tan x$ $\left[-\frac{\pi}{4}, \frac{\pi}{4}\right]$

8. $f(x) = |6 - 4x|$ $[-3, 3]$

9. What is the smallest possible slope to
 $y = x^3 - 3x^2 + 5x - 1$

10. If a particle moves along a straight line according to
 $s(t) = t^4 - 4t^3 + 6t^2 - 20$, find

- a) the maximum & minimum velocity on $0 \leq t \leq 3$.
b) the maximum & minimum acceleration on $0 \leq t \leq 3$.

Newton's Method of Roots - Classwork

The concept of Newton's method of finding roots is based on making an initial guess x_0 of the root of the function $f(x)$. From there, you come up with a series of x_i , which will be successively closer to the root of $f(x)$.

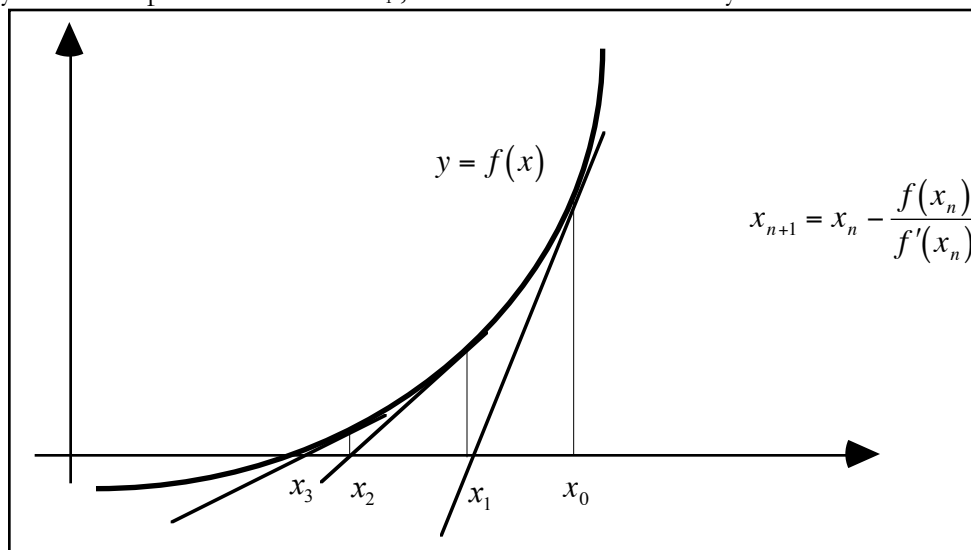

Sample problems - do by hand. You may use your calculators only for basic operations. Complete two iterations of Newton's method using the indicated initial guess.

1. $f(x) = x^2 - 2$ $x_1 = 1$

x_n	$f(x_n)$	$f'(x_n)$	$\frac{f(x_n)}{f'(x_n)}$

2. $f(x) = x^3 - x^2 - 2x - 2$ $x_1 = 2$

x_n	$f(x_n)$	$f'(x_n)$	$\frac{f(x_n)}{f'(x_n)}$

1. On all calculators, place the function which you wish the solution to in Y1.
2. Place the derivative of the function in Y2.
3. It is best to set your MODE to FLOAT giving the maximum amount of accuracy. However, if you are asked to apply Newton until two approximations differ by less than d decimal places, you may wish to set your MODE to d decimal places first.
4. Make your initial Guess and store it as X. Then type X-Y1/Y2 STO X. You will get the first iteration.
5. Press ENTER and you will get successive iterations.
6. To do another problem, simply repeat the steps above. You can use 2nd ENTER so you do not have to type the command on line 4.

3. Find the roots of $f(x) = 5x^2 - 4x - 7$

4. Find the smallest positive root of $f(x) = \sin x - x^2 + 1$

Warning: Do not depend on this routine on the A.P. exam. They usually give you a problem to calculate a root of a function through one or two iterations where calculators are not allowed. You must know the formula and how to apply it algebraically. Newton's method fails if the derivative of the function is zero at your original guess.

Newton's Method of Roots - Homework

In the following exercises, use Newton's Method by hand to find the first iteration in approximating the zeros and continue the process with the calculator until 2 successive approximations differ by less than .001.

1. $f(x) = x^3 + x + 3$ (Initial Guess = 1)

2. $f(x) = x^5 + x + 3$ (Initial Guess = 1)

3. $f(x) = x^2 - \frac{1}{x-1}$ (Initial Guess = 3)

4. $f(x) = x^4 - 10x^2 - 7$ (Initial Guess = 3)

5. $f(x) = 2x + \sin(x+1)$ (Initial Guess = $-\frac{\pi}{6}$)

6. $f(x) = x^3 - \cos x + 2$ (Initial Guess = 3)

7. $f(x) = \sin x$ has a root at $x = 0$. Suppose your initial guess is 1.3. Show that Newton's method does not work here and formulate a reason why it does not. Look at the picture visually in order to understand what is happening.

8) Newton's method can be used to determine square roots. For $x = \sqrt{a}$, use the equation $f(x) = x^2 - a$. Use this method to find $\sqrt{7}$ and $\sqrt{214}$. Use this method to find $\sqrt[5]{5}$

9. Show that Newton's method fails to converge for the function $f(x) = x^{1/3}$ using $x_1 = .1$

Approximation using Differentials - Classwork

We've defined $\frac{dy}{dx}$ to be $\lim_{\Delta x \rightarrow 0} \frac{\Delta y}{\Delta x}$. In this section, we give separate meanings to Δx , Δy , dx , dy .

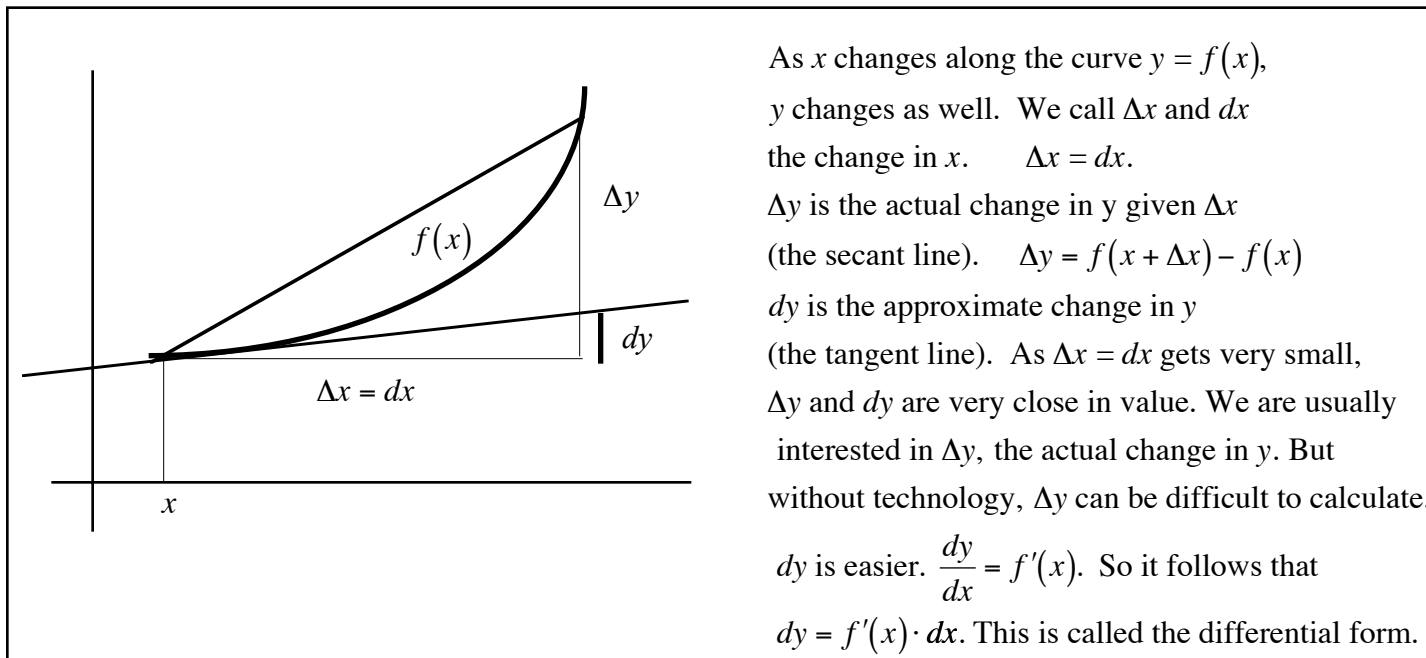

Example 1: $y = f(x) = 3x^2 - 8x + 2$ Find Δy and dy when $x = 1$ and $\Delta x = dx = .01$.

$$\Delta y = f(x + \Delta x) - f(x)$$

$$dy = f'(x) \cdot dx$$

Example 2: Compare Δy and dy as x changes from 2 to 2.01 given $f(x) = x^3 - x^2 + 3x - 2$

$$\Delta y = f(x + \Delta x) - f(x)$$

$$dy = f'(x) \cdot dx$$

Example 3) Find the approximate error in calculating the volume of a sphere if the radius is measured to be 5 inches with a measurement error of ± 0.1 inches. Find the relative percentage error $\frac{dv}{V}$ as well.

Approximation using Differentials - Homework

Use differentials to compute Δy and dy given $f(x)$, x , and $\Delta x = dx$.

1. $y = 5x^2 - 9x - 5$

$x = 2, \Delta x = dx = .01$

2. $f(x) = 2x^3 - 4x^2 - 6x + 5$

$x = 1, \Delta x = dx = .01$

3. $f(x) = \frac{1}{x^2}$

$x = 2, \Delta x = dx = .01$

4. The side of a square is measured to be 10 feet with a possible error of ± 0.1 ft. What is the difference between the true greatest possible error in computing the area of the square and its approximation using differentials. Find the relative percentage error between the approximate error and true area.
5. An 8 inch tall cylindrical coffee can has a 6 inch diameter with a possible error of $.02$ inch. What is the difference between the true greatest possible error in computing the volume of the can and its approximation using differentials. Find the relative percentage error between the approximate error and true volume.
6. On roads in hilly areas, you sometimes see signs like this:

Steep hill
20% Grade

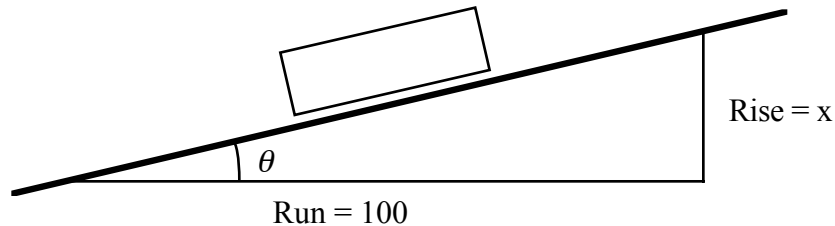

The grade of a hill is the slope (rise/run) written as a percentage, or, equivalently, the number of feet the hill rises per hundred feet horizontally. The figure above shows the latter meaning of grade.

- a) Let x be the grade of a hill. Explain why the angle, θ degrees, that a hill makes with the horizontal is

given by $\theta = \frac{180}{\pi} \tan^{-1} \frac{x}{100}$

- b) An equation for $d\theta$ is $d\theta = \left(\frac{180}{\pi}\right) \frac{100}{x^2 + 10000} dx$. You can estimate θ at $x = 20\%$ simply by multiplying $d\theta$ at $x = 0$ by 20. How much error is there in the value of θ found by this way rather than using the exact formula which involves the \tan^{-1} function?

- c) A rule of thumb you can use to estimate the number of degrees a hill makes with the horizontal is to divide the grade by 2. When you use this method to determine the the number of degrees for a 20 % grade, how much error is there in the number?

Optimization Problems - Classwork

Many times in life we are asked to do an optimization problem - that is, find the largest or smallest value of some quantity that will fulfill a need. Typical situations are:

- find the route which will minimize the time it takes me to get to school.
- build a structure using the least amount of material.
- build a structure costing the least amount of money.
- build a yard enclosing the most amount of space.
- find the least medication one should take to help a medical problem.
- find how the most one should charge for a CD in order to make as much money as possible.

All of these situations have something in common - they are all trying to maximize or minimize some quantity. This lends itself to a calculus solution. We have spent the better part of last month trying to find maximum and minimum values of functions. In every optimization problem, you are always looking for a quantity to be maximized or minimized. So in solving word problems, you must look carefully for certain words among all the verbiage. Look for words like “minimize area”, “smallest volume”, “least amount of time”, “shortest distance”, “cheapest price.” On the following pages, there are a wealth of problems. Quickly examine each and underline the key words which tell you what kind of problem it is.

Methods for Solving Optimization Problems

1. Assign variables to all given quantities and quantities to be determined. Don't be afraid to use letters you usually do not use (p, m, g , etc.). When feasible, make a sketch of the problem.
2. Making a chart of possible answers allows you to see a relationship between variables. While not necessary, it is helpful.
3. Write a “primary” equation for the quantity you found that needs to be maximized or minimized
Area of Rectangle = length • width
Distance = rate • time
Volume of rectangular solid = length • width • height
Hypotenuse = $\sqrt{x^2 + y^2}$
Perimeter of rectangle = $2 \cdot \text{length} + 2 \cdot \text{width}$
Volume of cylinder = $\pi(\text{radius}^2) \cdot \text{height}$
4. Reduce the right side of this “primary equation” to one having a single variable. If there is more than one variable on the right side, you must write a “secondary” equation (a restriction or constraint) relating the variables of the primary equation.
5. Take the derivative of the equation and **set equal to zero**. If you get more than one answer, make a sign chart to determine whether it represents a maximum or minimum. Pay attention to whether that value makes sense. Time is rarely negative (it can't take negative 7 hours to run a race). You cannot use more than you have (you can't have a length of 8 feet when you only have 6 feet of fencing).
6. **Be sure that you answer the question that is asked.** If you are asked to find a minimum or maximum value of some quantity, you must plug your answer from (4) into your primary equation.
7. If you are to find a maximum or minimum on a closed interval, you must test the endpoints as well. Make sure your work is clear.
8. You can verify your answers by graphing your primary equation with one variable on the calculator. Use your 2nd CALC maximum or minimum function.

Example 1) Two numbers add up to 40. Find the numbers that maximize their product.

Smaller Number						
Larger Number						
Product						

Primary

Secondary

Example 2) A rectangle has a perimeter of 71 feet. What length and width should it have so that its area is a maximum? What is this maximum area?

Width						
Length						
Area						

Primary

Secondary

Example 3) Find two positive numbers that minimize the sum of twice the first number plus the second if the product of the two numbers is 288.

First Number						
Second Number						
Sum						

Primary

Secondary

Example 4) An open box is to be made from a piece of metal 16 by 30 inches by cutting out squares of equal size from the corners and bending up the sides. What size square should be cut out to create a box with greatest volume. What is the maximum volume as well?

Primary

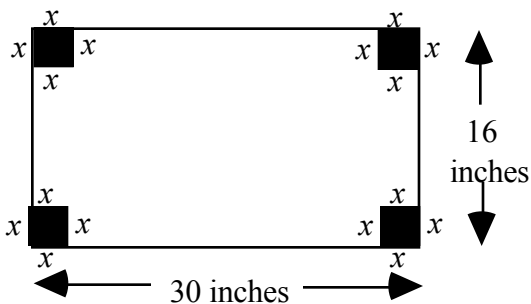

Example 5) I am 1 mile in the ocean and wish to get to a town 3 miles down the coast which is very rocky. I need to swim to the shore and then walk along the shore. What point should I swim to along the shoreline so that the time it takes to get to town is a minimum? I swim at 2 mph and walk at 4 mph.

Primary

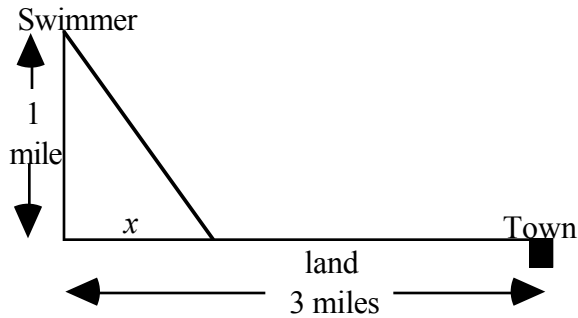

Example 6) . Find the dimensions of the largest area rectangle which can be inscribed into a circle of radius 4 inches.

primary

secondary

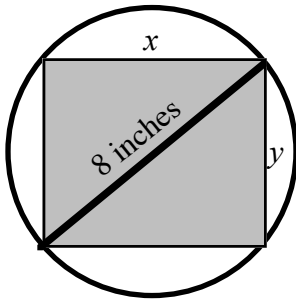

How would this problem change if the radius were r inches?

Example 7) A 6-oz. can of Friskies Cat food contains a volume of approximately 14.5 cubic inches. How should the can be constructed so that the material made to make the can is a minimum?

Primary

Secondary

Surface Area = Area of side + Area of Top & bottom

$V = \pi r^2 h$

$$S = 2\pi r h + 2\pi r^2$$

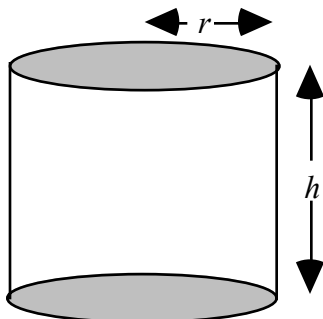

Optimization Problems - Homework

1. Find two numbers whose sum is 10 for which the sum of their squares is a minimum.
2. Find nonnegative numbers x and y whose sum is 75 and for which the value of xy^2 is as large as possible.
3. A ball is thrown straight up in the air from ground level. Its height after t seconds is given by $s(t) = -16t^2 + 50t$. When does the ball reach its maximum height? What is its maximum height?
4. A farmer has 2,000 feet of fencing to enclose a pasture area. The field will be in the shape of a rectangle and will be placed against a river where there is no fencing needed. What is the largest area field that can be created and what are its dimensions?



5. A fisheries biologist is stocking fish in a lake. She knows that when there are n fish per unit of water, the average weight of each fish will be $W(n) = 500 - 2n$, measured in grams. What is the value of n that will maximize the total fish weight after one season. *Hint: Total Weight = number of fish • average weight of a fish.*

6. The size of a population of bacteria introduced to a food grows according to the formula $P(t) = \frac{6000t}{60 + t^2}$ where t is measured in weeks. Determine when the bacteria will reach its maximum size. What is the maximum size of the population?

7. The U.S. Postal Service will accept a box for domestic shipping only if the sum of the length and the girth (distance around) does not exceed 108 inches. Find the dimensions of the largest volume box with a square end that can be sent.

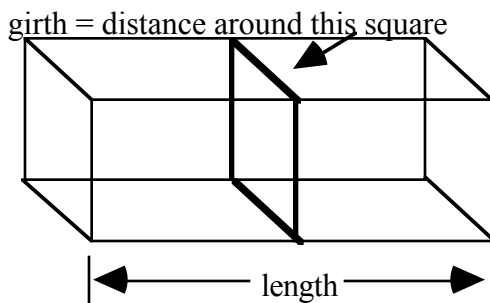

8. Blood pressure in a patient will drop by an amount $D(x)$ where $D(x) = 0.025x^2(30 - x)$ where x is the amount of drug injected in cm^3 . Find the dosage that provides the greatest drop in blood pressure. What is the drop in blood pressure?

9. A wire 24 inches long is cut into two pieces. One piece is to be shaped into a square and the other piece into a circle. Where should the wire be cut to maximize the total area enclosed by the square and circle?

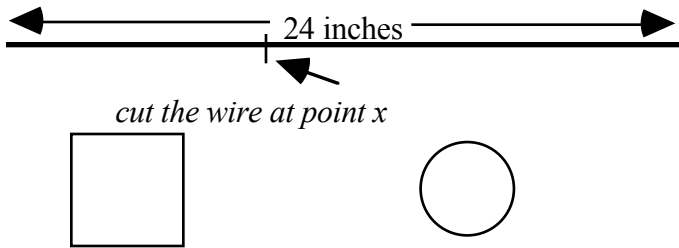

Let x be the point where the cut is made. Assume the square is on the left and the circle on the right. Complete the chart.

x	4	8	12	20	x
Area square					
Area circle					
Total area					

10. A designer of custom windows wishes to build a Norman Window with a total outside perimeter of 60 feet. How should the window be designed to maximize the area of the window. A Norman Window contains a rectangle bordered above by a semicircle.

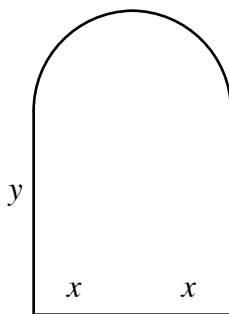

11. Alaina wants to get to the bus stop as quickly as possible. The bus stop is across a grassy park, 2,000 feet east and 600 feet north of her starting position. Alaina can walk along the edge of the park on the sidewalk at a speed of 6 feet/sec. She can also travel through the grass in the park, but only at a rate of 4 ft/sec (dogs are walked here, so she must move with care). What path will get her to the bus stop the fastest?

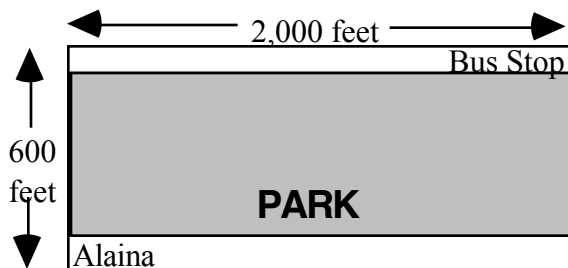

12. On the same side of a straight river are two towns, and the townspeople want to build a pumping station, **S**, that supplies water to them. The pumping station is to be at the river's edge with pipes extending straight to the two towns. The distances are shown in the figure below. Where should the pumping station be located to minimize the total length of pipe?

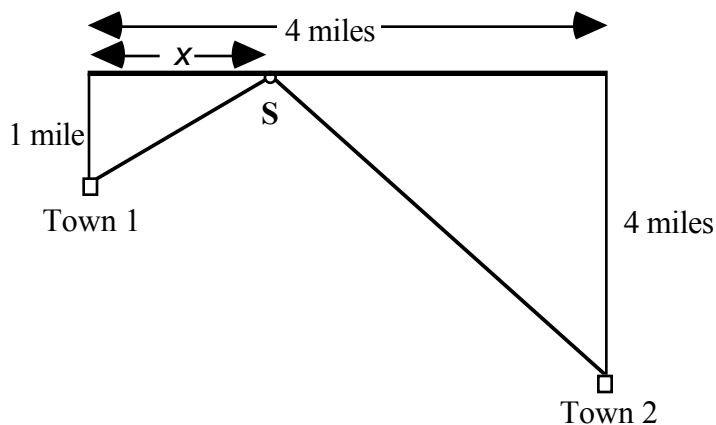

13. A physical fitness room consists of a rectangular region with a semicircle on each end. If the perimeter of the room is to be a 200-meter running track, find the dimensions that will make the area of the rectangular region as large as possible.

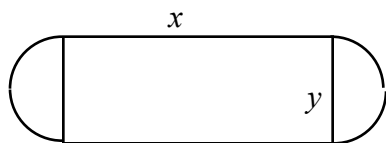

Total distance around track = 200 meter

14. Below is the graph of $y = 1 - x^2$. Find the point on this curve which is closest to the origin. (Remember, you need a primary equation. What is it that you wish to minimize?)



Economic Optimization Problems - Classwork

Example 1) A trucking company has determined that the cost per hour to operate a single truck is given by $C(s) = 0.0001s^2 - 0.01s + 112$ where s is the speed that the truck travels. At what speed is the total cost per hour a minimum? What is the hourly cost to operate the truck?

Example 2) A nursery wants to add a 1,000-square-foot rectangular area to its greenhouse to sell seedlings. For aesthetic reasons, they have decided to border the area on three sides by cedar siding at a cost of \$10 per foot. The remaining side is to be a wall with a brick mosaic that costs \$25 per foot. What should the dimensions of the sides be so that the cost of the project will be minimized?

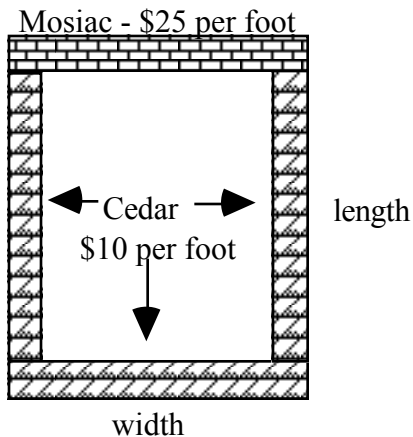

Width	Length	Cedar Cost	Mosaic Cost	Total Cost
x				

Example 3) A real estate company owns 100 apartments in New York City. At \$1,000 per month, each apartment can be rented. However, for each \$50 increase, there will be two additional vacancies. How much should the real estate company charge for rent to maximize its revenues?

\$50 increases	Rent	Apts. rented	Revenue
0			
1			
2			
3			
4			
50			
x			

Example 4) A closed box with a square base is to have a volume of $1,800 \text{ in}^3$. The material for the top and bottom of the box costs \$3 per square inch while the material for the sides cost \$1 per square inch. Find the dimensions of the box that will lead to the minimum total cost. What is the minimum total cost?

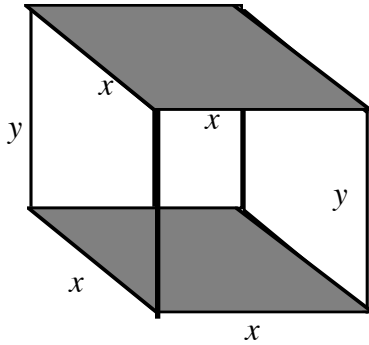

Example 5. A telephone wire is to be laid from the telephone company to an island 7 miles off shore at a cost of \$200,000 per mile along the shoreline and \$300,000 per mile under the sea. How should the wire be laid at the least expensive cost if the distance along the shoreline is 12 miles. What is that cost?

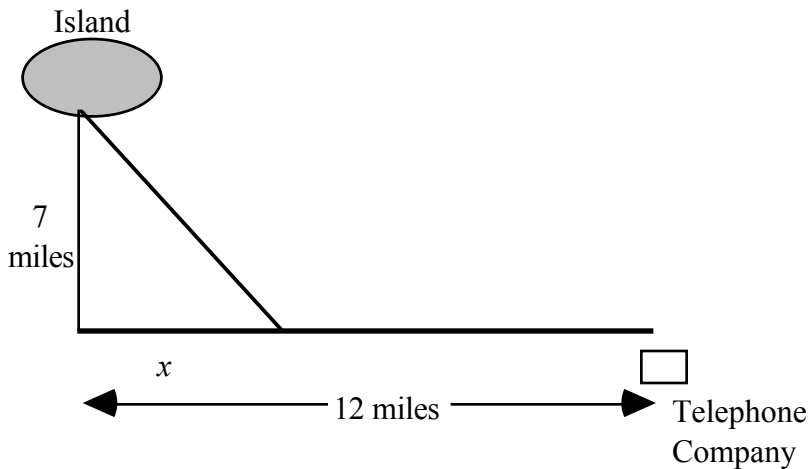

x	water cost	land cost	total cost
0			
12			
x			

Example 6) A small television company estimates that the cost (in dollars) of producing x units of a certain product is given by $800 + .04x + .00002x^2$. Find the production level that minimizes the average cost per unit.

Units	Cost	Average Cost
100		
1,000		
5,000		
10,000		

Economic Optimization Problems - Homework

1. The profit for Ace Advertising Co. is $P = 230 + 20s - \frac{1}{2}s^2$ where s is the amount (in hundreds of dollars) spent on advertising. What amount of advertising gives the maximum profit?

2. North American Van Lines calculates charges for delivery according to the following rules.

$$\text{Fuel cost} = \frac{v^2}{120} \text{ per hour} \qquad \text{Driver cost} = \$30 \text{ per hour}$$

Find the speed v that a truck should travel in order to minimize costs for a trip of 120 miles. *Hint: remember that rate • time = distance. Make a chart of possible speeds v and total costs.*

3. Normally a pear tree will produce 30 bushels of pears per tree when 20 (or fewer) pear trees are planted per acre. However, for each additional pear tree planted above 20 trees per acre, the yield per tree will fall by one bushel per tree (why?). How many trees should be planted per acre to maximize the total yield? *Hint: Make a chart like the Apartment Housing sample problem.*
4. Midas Muffler charges \$28 to replace a muffler. At this rate, the company replaces 75,000 mufflers per week nationally. For each additional dollar that the company charges, it tends to lose 1,000 customers a week. For each dollar the company subtracts from the \$28, the company gains 1,000 per week. How much should Midas charge to change a muffler in order to maximize their revenue? What would that revenue be? *Hint: Make a chart like the Apartment Housing sample problem.*

5. A concert promoter knows that 5,000 people will attend an event with tickets set at \$50. For each dollar less in ticket price, an additional 1,000 tickets will be sold. What should the price of a ticket be in order to maximize the total receipts. *Hint: Make a chart like the Apartment Housing sample problem.*
6. A travel agent is offering charter holidays in the Bahamas for college students. For groups of size up to 100, the fare is \$1,000 per student. For larger groups, the fare per person decreases by \$5 for each additional person in excess of 100. Find the size of the group that will maximize the travel agent's revenues. *Hint: Make a chart like the Apartment Housing sample problem.*
7. A real estate office handles 50 apartment units. When the rent is \$540 per month, all units are occupied. However, on the average, for each \$30 increase in rent, one unit becomes vacant. Each occupied unit requires an average of \$36 per month for service and repairs. What rent should be charged to realize the most profit?

8. A power station is on one side of a river that is .5 mile wide, and a factory is 6 miles downstream on the other side. It costs \$6,000 per mile to run power lines overland and \$8,000 per mile to run them underwater. Find the most economical path to lay transmission lines from the station to the factory.

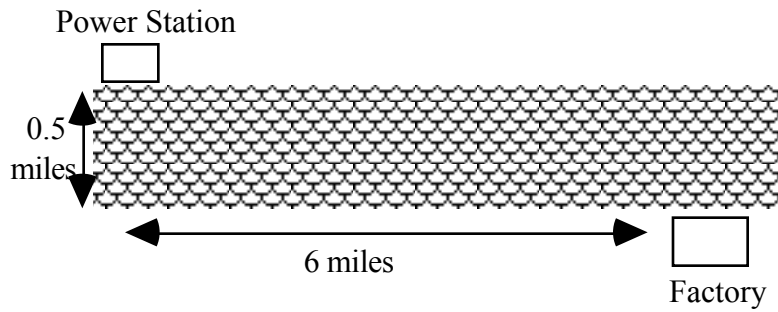

9. A rectangular area is to be fenced in using two types of fencing. The front and back uses fencing costing \$5 a foot while the sides uses fencing costing \$4 a foot. If the area of the rectangle must contain 500 square feet, what should be the dimensions of the rectangle in order to keep the cost a minimum?

10. The same rectangular area is to be built, but now the builder has only \$800 to spend. What is the *largest area* that can be fenced in using the same two types of fencing mentioned above.

Indefinite Integration - Classwork

Take a piece of notebook paper and cover up the paragraph under the chart below. Below, there are 5 terms. Write what you feel are the inverses of each of these terms.

term	5	1/3	boy	dog	hot dog
its inverse					

As ridiculous as the last problem is (how can you have an inverse of a hot dog?) so are they all ridiculous. The problem is that all of these terms above are nouns. Inverses refer not just to an opposite but to an opposite process. We take inverses of verbs, not nouns. Write the inverses of these processes.

process	sit down	get dressed	take a book home	get wet	go to sleep
its inverse					

In mathematics, you have learned about operations on functions f . The inverse operation is denoted as f^{-1} (not to be confused with x^{-1} , the reciprocal of x (remember x is a noun and f is a process which is a verb.) When ever you perform an operation and immediately perform its inverse, you will end up exactly where you started with. We say that $f^{-1}[f(x)] = x$ and also $f[f^{-1}(x)] = x$. Below write some mathematical functions and their inverses.

Function	Inverse

Function	Inverse

So, obviously since differentiation of functions is a process, we must have an inverse of that process. We call that process antidifferentiation. For instance, we know that the derivative of $y = x^3$ is $3x^2$. So it makes sense to say that an antiderivative of $3x^2$ is x^3 .

However, it is important to say *an* antiderivative of $3x^2$ rather than *the* antiderivative of $3x^2$ for the simple reason that the derivative of $y = x^3$ is $3x^2$, but so is the derivative of $y = x^3 + 2$, $y = x^3 - 5$, and $y = x^3 + 6\pi$. There are an infinite number of functions whose derivative is $3x^2$. So when we go backwards to the antiderivative it is impossible to determine which function it came from. So to cover our bets, we say that the antiderivative of $3x^2$ is $x^3 + C$, where C represents a constant. We call C the constant of integration. It is important to attach the $+C$ after every antiderivative. What you are doing is saying that the antiderivative is a family of functions rather than one specific function.

The process of taking antiderivatives is called *integration*, specifically *indefinite integration* because of the constant of integration C . So we do not have to write the word antiderivative again, we use a symbol to represent an antiderivative. That symbol is called an integral sign which is written like this: \int . The way we write an integral is:

$$\int f(x) dx = F(x) + C. \text{ The } dx \text{ tells you what the important variable is when you are integrating}$$

just as you need to know what the important variable is when you differentiate $\left(\frac{dy}{dt} \text{ as opposed to } \frac{dy}{dx}\right)$.

So, since $\frac{d}{dx}(4x) = 4$, we will say that $\int 4 dx = 4x + C$ and

and since $\frac{d}{dx}(x^2 + 3x - 1) = 2x + 3$, we will say that $\int (2x + 3) dx = x^2 + 3x + C$

Just as we have derivative rules, we have a corresponding rule for integrals. Here are some basic integration rules.

<u>Differentiation formula</u>	<u>Integration formula</u>
$\frac{d}{dx}[C] = 0$	$\int 0 dx = C$
$\frac{d}{dx}[kx] = k$	$\int k dx = kx + C$
$\frac{d}{dx}[kf(x)] = kf'(x)$ a constant can be “factored out”	$\int kf(x) dx = k \int f(x) dx + C$ - factor out constant
$\frac{d}{dx}[f(x) \pm g(x)] = f'(x) \pm g'(x)$ the derivative of a sum is the sum of derivatives	$\int [f(x) \pm g(x)] dx = \int f(x) dx + \int g(x) dx + C$ integral of a sum is the sum of the integrals
$\frac{d}{dx}[x^n] = nx^{n-1}$ - the power rule	$\int x^n dx = \frac{x^{n+1}}{n+1} + C$ - the power rule reversed

Examples - find the integral of each of the following:

1) $\int 7 dx$

2) $\int x^5 dx$

3) $\int x^{12} dx$

4) $\int (x^4 - x^2) dx$

5) $\int (t^3 + t + 1) dt$

6) $\int 3x^3 dx$

7) $\int (2x^2 - 7x - 8) dx$

8) $\int \left(\frac{3}{4}x^5 + \frac{5}{3}x^2 - \frac{x}{2} \right) dx$

9) $\int \left(\pi x + \frac{1}{\pi} \right) dx$

10) $\int \frac{1}{x^2} dx$

11) $\int \left(\frac{4}{x^3} - \frac{5}{x^4} \right) dx$

12) $\int \sqrt{x} dx$

13) $\int (2\sqrt[3]{y} - 4\sqrt[4]{y}) dy$

14) $\int \left(\frac{1}{\sqrt{x}} - x^{2/3} \right) dx$

15) $\int (x^\pi + \sqrt{\pi}) dx$

In taking integrals, you may have to be clever. There are only a certain set of rules and if an integration problem doesn't fit one of the rules, you may have to change the expression so that it does. I call this a “bag of tricks.”

Trick 1 - multiply out, then integrate

16) $\int (2x - 3)^2 dx$

Trick 2 - Split into individual fractions, then integrate

17) $\int \frac{x^2 + 3x + 1}{x^4} dx$

18) $\int \frac{(2x - 5)(3x + 2)}{\sqrt{x}} dx$

We took derivatives of trig functions earlier in the year. So, naturally, we should be able to go backwards and take integrals involving trig functions.

Differentiation formula	Integration formula
$\frac{d}{dx}[\sin x] = \cos x$	$\int \cos x \, dx = \sin x + C$
$\frac{d}{dx}[\cos x] = -\sin x$	$\int \sin x \, dx = -\cos x + C$
$\frac{d}{dx}[\tan x] = \sec^2 x$	$\int \sec^2 x \, dx = \tan x + C$
$\frac{d}{dx}[\csc x] = -\csc x \cot x$	$\int \csc x \cot x \, dx = -\csc x + C$
$\frac{d}{dx}[\sec x] = \sec x \tan x$	$\int \sec x \tan x \, dx = \sec x + C$
$\frac{d}{dx}[\cot x] = -\csc^2 x$	$\int \csc^2 x \, dx = -\cot x + C$

Differentiation and integration using the sine and cosine functions occur in calculus all the time and students always get confused with signs. A good way to remember is to follow this chart.

	sin		
	◇		
	cos		
	◇		
Differentiation	- sin	Integration	When you differentiate, you follow the chart down.
	◇		
	- cos		When you integrate, you follow the chart up.
	◇		
	sin		

Examples - find the integral of each of the following:

20) $\int 4 \sin x \, dx$

21) $\int \frac{-2 \cos x}{3} \, dx$

22) $\int \frac{5}{\cos^2 x} \, dx$

23) $\int (4 \cos x - 9 \sin x) \, dx$

24) $\int \left(\frac{-\sin x}{\cos^2 x} \right) \, dx$

25) $\int (\theta^2 - 2 \csc^2 \theta) \, d\theta$

If you were given the statement that $\frac{dy}{dx} = 4x$, we can cross multiply to get $dy = 4x dx$. We can now integrate each side of the equation to get $\int dy = \int 4x dx$. From there, we can solve for y .

The original statement $\frac{dy}{dx} = 4x$ is called a differential equation (DEQ). In a differential equation, you are given a statement about the derivative of y , $\frac{dy}{dx}$. Your goal is to solve for y . We have done so with the exception of the $+C$, the constant of integration. So we have a *general solution* of the DEQ. But suppose we were told that if $x = 0$, then $y = 5$. From there we can solve for C and we will thus have the *specific solution* of the DEQ. Let's do so.

Example 18) Solve the differential equation.

$$f'(x) = 3x - 1, f(2) = 3$$

Example 19) Solve the differential equation.

$$f'(x) = x^2 - 2x + 2, f(3) = -1$$

Example 20) Solve the differential equation.

$$f''(x) = 2, f'(4) = 1, f(-1) = 2$$

Example 21) Solve the differential equation.

$$f''(x) = 2x, f'(-5) = 30, f(2) = -1$$

Example 22) Given that the graph of $f(x)$ passes through the point $(1, 6)$ and that the slope of its tangent line at $(x, f(x))$ is $2x + 1$, find $f(6)$.

Indefinite Integration - Homework

1. $\int -9 \, dx$

2. $\int -5x \, dx$

3. $\int (6+2x) \, dx$

4. $\int x^7 \, dx$

5. $\int (x^4 + x^3 - x^2) \, dx$

6. $\int (3x^3 - 4x^2) \, dx$

7. $\int \left(\frac{2}{3}x^5 - \frac{5}{2}x + \frac{1}{2} \right) dx$

8. $\int \left(\frac{3}{x^4} \right) dx$

9. $\int \left(2 - \frac{1}{x^5} + \frac{7}{x^3} \right) dx$

10. $\int 5\sqrt{x} \, dx$

11. $\int 5(\sqrt[5]{x}) \, dx$

12. $\int \left(x^{3/4} - \frac{1}{x^{3/4}} \right) dx$

13. $\int 3\sqrt[3]{x^2} \, dx$

14. $\int (x-5)^2 \, dx$

15. $\int 4(3x-2)^3 \, dx$

16. $\int \frac{x^3 - 4x - 1}{2x^3} \, dx$

17. $\int t^2(3+t)^2 \, dt$

18. $\int \frac{(3x-2)^2}{\sqrt{x}} \, dx$

19. $\int \frac{3\cos x}{5} dx$

20. $\int (1 - 6\cos x) dx$

21. $\int \left(\frac{1}{x^2} - \sin x \right) dx$

22. $\int (\sec^2 t + \cos t + 1) dt$

23. $\int (\sin^2 x + \cos^2 x) dx$

24. $\int \frac{\sin x}{1 - \sin^2 x} dx$

Solve the following differential equations.

25. $f''(x) = 2, f'(1) = 4, f(2) = -2$

26. $f''(x) = 2x, f'(2) = -1, f(3) = 1$

27. $f''(x) = \frac{1}{x^{3/2}}, f'(4) = 2, f(0) = 1$

28. $f''(x) = \cos x, f'(\pi) = 2, f(\pi) = -1$

u-Substitution - Classwork

When you take derivatives of more complex expressions, you frequently have to use the chain rule to differentiate. The integration equivalent of the chain rule is called *u-substitution*. *u-substitution* allows you integrate expressions which do not appear integratable.

1) $\int x(x^2 - 1)^5 dx$ Set up a $u =$ _____. Find $\frac{du}{dx} =$ _____. Solve for $du =$ _____

You need to manufacture your du in the original expression. So you will have to multiply by _____ on the inside and thus multiply by _____ on the outside. Now change everything to u .

Now integrate in terms of u .

Finally, change back to the variable x and add C .

2) $\int (3x - 2)^4 dx$

3) $\int \sqrt{5x - 2} dx$

4) $\int 4(6x - 1)^{\frac{2}{3}} dx$

5) $\int x\sqrt{x^2 - 2} dx$

6) $\int x^2\sqrt{1 - 4x^3} dx$

7) $\int \frac{x}{\sqrt[3]{2x^2 - 1}} dx$

8) $\int x^{1/2}(x^{3/2} + 2)^9 dx$

9) $\int (x + 2)\sqrt{x^2 + 4x - 3} dx$

10) $\int (x+2)\sqrt{x-4} dx$

11) $\int \frac{x-5}{\sqrt{x-6}} dx$

12) $\int \frac{x^2}{\sqrt{x+1}} dx$

13) $\int \cos 4x dx$

14) $\int 3\sin(1-3x) dx$

15) $\int \sin^3 x \cos x dx$

16) $\int \tan 10x \sec 10x dx$

17) $\int \tan^2 x \sec^2 x dx$

18) $\int \sin x \sqrt{\cos x} dx$

19) $\int \frac{\cos x}{\sqrt{1-\sin x}} dx$

u-Substitution - Homework

1. $\int \sqrt{x-2} \, dx$

2. $\int (2x+3)^{11} \, dx$

3. $\int \sqrt{5x-1} \, dx$

4. $\int \sqrt[3]{6x+1} \, dx$

5. $\int 5(3-4x)^{2/3} \, dx$

6. $\int \frac{dx}{(8x-1)^3}$

7. $\int x(x^2+2)^6 \, dx$

8. $\int 6x^2 \sqrt{3x^3-1} \, dx$

9. $\int \left(1 + \frac{1}{x}\right)^3 \left(\frac{1}{x^2}\right) \, dx$

10. $\int x^{1/3} \left(x^{4/3} + 9\right)^8 \, dx$

11. $\frac{2}{3} \int \sqrt{4 - \frac{3}{5}x} \, dx$

12. $\int (3x+15)\sqrt{x^2+10x+4} \, dx$

13. $\int (x+2)\sqrt{x-2} \, dx$

14. $\int \frac{x^2}{\sqrt{x-4}} \, dx$

15. $\int \sin 5x \, dx$

16. $\int \cos \frac{x}{2} \, dx$

17. $\int \frac{1}{3} \sec^2 8x \, dx$

18. $\int \sin 4x \cos 4x \, dx$

19. $\int \cos^3 x \sin x \, dx$

20. $\int \tan x \sec^2 x \, dx$

21. $\int \sqrt{\cos 6x} \sin 6x \, dx$

22. $\int \frac{\sin x}{(4 - \cos x)^3} \, dx$

Sigma Notation - Classwork

We will switch gears for a section and learn a completely different type of problem. It will be apparent within a few sections why we are seemingly learning something unrelated to integration.

Suppose you were asked to find the sum of the first 5 terms of the following sequence:

$$1 + 2 + 4 + \dots = \underline{\hspace{2cm}} \quad \text{How did you arrive at the answer? } \underline{\hspace{4cm}}$$

The problem with writing such addition problems with the ellipsis (...), is that the rule for each term is not apparent. We introduce notation called **sigma notation** for such problems using the Greek letter sigma Σ .

The sum of n terms $a_1 + a_2 + a_3 + \dots + a_n$ is written as $\sum_{i=1}^n a_i$ where i is the index of summation and a_i is the i th term of the sum. Note that sigma notation does not help you to calculate the sum, only to write the sum.

Examples - Find the following sums.

1) $\sum_{i=1}^8 3$

2) $\sum_{i=1}^6 i$

3) $\sum_{j=1}^7 j^2$

4) $\sum_{k=-2}^3 k^3$

Since $\sum_{i=1}^n a_i$ represents a summation of numbers, we can apply basic properties of addition and multiplication.

$$\sum_{i=1}^n k a_i = k \sum_{i=1}^n a_i \quad (\text{meaning you can factor out } k)$$

$$\sum_{i=1}^n [a_i \pm b_i] = \sum_{i=1}^n a_i \pm \sum_{i=1}^n b_i \quad (\text{write one sum as 2 sums})$$

Find the following sums (calculators allowed)

5) $\sum_{i=1}^7 8i$

6) $\sum_{i=1}^5 [5i - 2]$

7) $\sum_{i=1}^5 [(i+2)(i+3)]$

8) $\sum_{i=1}^8 \frac{i}{3}$

9) $\sum_{i=1}^6 \frac{i-2}{i}$

10) $\sum_{i=2}^8 \sqrt{i^2 - 1}$

11) $\sum_{i=1}^{100} (-1)^i$

12) $\sum_{i=0}^{10} (-1)^i i^2$

Technology: You can use your TI-84 to generate and add terms of these sequences. To create a sequence you will use the SEQ command found in 2nd LIST OPS. The format of this command is Seq(formula in x , x , starting x , ending x). For instance, problem 5 above $\sum_{i=1}^7 8i$ would be Seq(8X,X,1,7). This will generate the sequence. Now to add the terms, you use the sum command found in 2nd LIST MATH. Use Sum(Ans). You can do this in one fell swoop: Sum(Seq(8X,X,1,7)). You may only sum up to 999 terms.

As quick as you can, find the sum $\sum_{i=1}^{15} i$. _____

Suppose you were asked to find the sum $\sum_{i=1}^{100} i$. Would you add all 100 terms? There must be an easier way.

$$\sum_{i=1}^{100} i = 1 + 2 + 3 + \dots + 50 + 51 + \dots + 98 + 99 + 100$$

Instead of adding your terms in sequential order, add the first plus the last, 2nd and next to last, etc. Each gives a sum of 101. Altogether you have 101 added 50 times or $50(101) = 5050$.

There are formulas you can use to add many terms. While it is not necessary that you memorize the formulas, you will find them extremely useful for difficult summations.

$$\sum_{i=1}^n c = cn$$

$$\sum_{i=1}^n i = \frac{n(n+1)}{2}$$

$$\sum_{i=1}^n i^2 = \frac{n(n+1)(2n+1)}{6}$$

$$\sum_{i=1}^n i^3 = \frac{n^2(n+1)^2}{4}$$

Examples - Find the following sums.

$$13) \sum_{i=1}^{45} 3i$$

$$14) \sum_{i=1}^{30} i^2$$

$$15) \sum_{i=1}^{50} (2i^2 - 1)$$

$$16) \sum_{i=1}^{60} (i^2 - 4i + 2)$$

$$17) \sum_{i=1}^{38} (3i - 5)^2$$

$$18) \sum_{i=1}^{20} (i^3 - i^2 + i)$$

Sigma Notation - Homework

For each problem, determine the sum by **generating each term** and calculate using the calculator.

$$1) \sum_{k=1}^6 (3k - 2)$$

$$2) \sum_{j=1}^{60} 2$$

$$3) \sum_{k=1}^{10} (k^2 - 1)$$

$$4) \sum_{k=1}^{10} (k - 1)^2$$

$$5) \sum_{i=1}^5 (i + 1)(2i - 3)$$

$$6) \sum_{i=1}^7 \frac{i}{i + 1}$$

$$7) \sum_{i=1}^6 \frac{4}{i^2 + 2}$$

$$8) \sum_{i=1}^8 (-1)^i i^3$$

$$9) \sum_{i=3}^9 \sqrt{2i}$$

$$10) \sum_{i=1}^5 (i^3 - (i + 1)^2)$$

Use your formulas and calculators to calculate the values of the following.

$$11) \sum_{i=1}^{17} 5i$$

$$12) \sum_{i=1}^{20} i^2$$

$$13) \sum_{i=1}^{20} (i^2 - 1)$$

$$14) \sum_{i=1}^{25} (i + 4)^2$$

$$15) \sum_{i=1}^{30} (i^3 + i)$$

$$16) \sum_{i=1}^{30} (i^3 - i^2)$$

$$17) \sum_{i=1}^{10} (i^3 + 2i^2 - 5i + 3)$$

$$18) \sum_{i=5}^{30} (2i^3 - i)$$

Area Under Curve - Classwork

One of the basic problems of calculus is to find the slope of the tangent line (i.e. the derivative) at any point on the curve. The other basic problem is to find the area under the curve, that is the area between the curve and the x -axis between any two values of x .

Below you are given a curve $y = f(x)$. Estimate what you think the area is. Then on the next three graphs, draw 2 rectangles, 4 rectangles, and 8 rectangles, total the areas of each and sum them for another estimate of the total area under the curve.

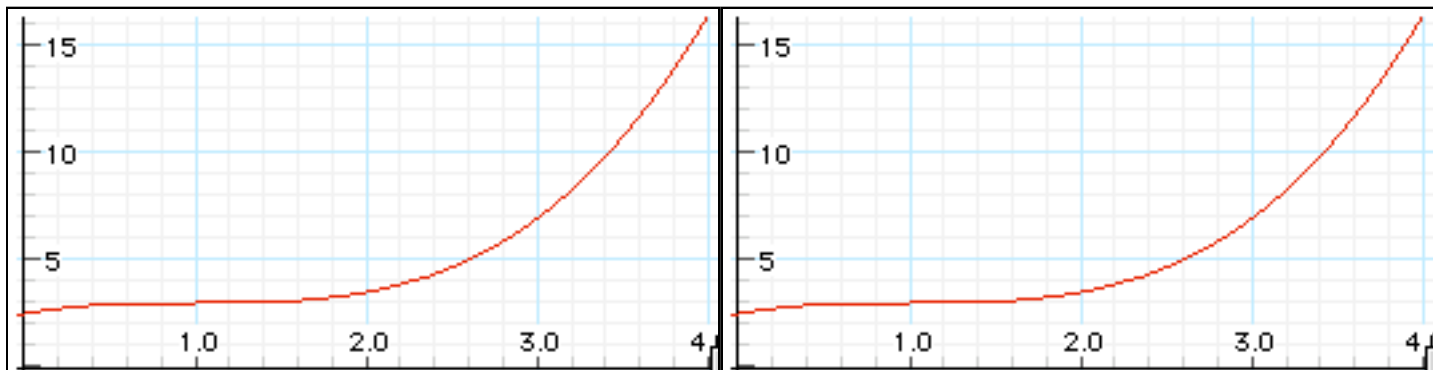

Estimate of area _____

2 Rectangles: _____ + _____ = _____

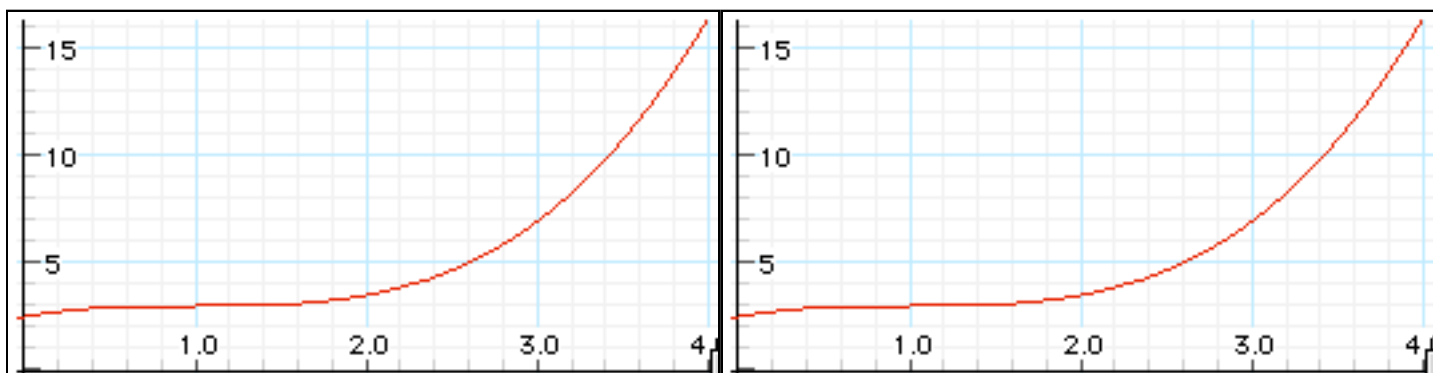

4 Rectangles: _____ + _____ + _____ + _____ = _____

8 Rectangles: _____ + _____ + _____ + _____ + _____ + _____ + _____ + _____ = _____

As you can see, as you use more rectangles, your estimate gets better but the amount of work you have to do increases. This is the idea we bring as we start our study of area. Now let's get more exact. Let's do the same thing with another curve, but this time you will be given the function: $f(x) = x^2 + 1$. Our problem is to estimate the area under the curve between $x = 0$ and $x = 4$ using "right" rectangles.

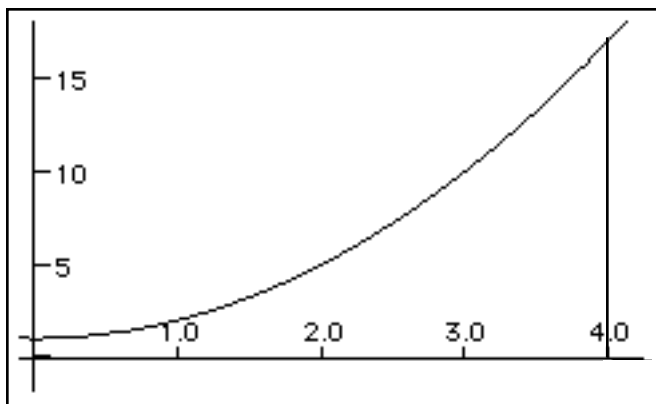

Estimate the area _____

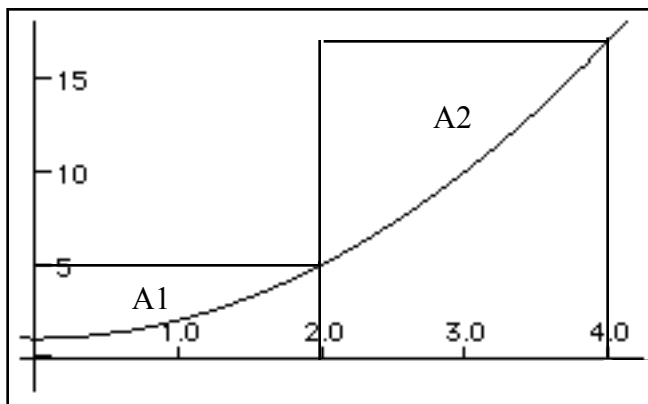

$$\text{Area} \approx A1 + A2 = b_1h_1 + b_2h_2$$

$$\text{Area} \approx b_1f(2) + b_2f(4) =$$

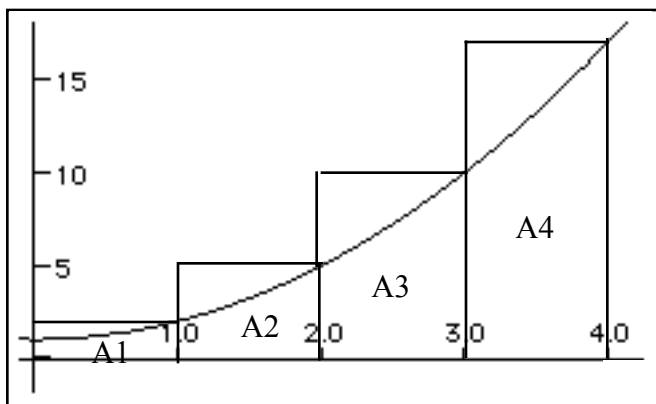

$$\text{Area} \approx A1 + A2 + A3 + A4$$

$$\text{Area} \approx b_1h_1 + b_2h_2 + b_3h_3 + b_4h_4$$

$$\text{Area} \approx b_1f(1) + b_2f(2) + b_3f(3) + b_4f(4) =$$

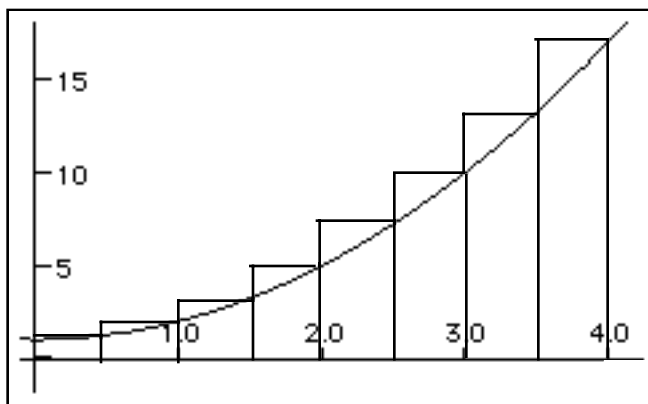

$$\text{Area} \approx A1 + A2 + A3 + A4 + A5 + A6 + A7 + A8$$

$$\text{Area} \approx b_1h_1 + b_2h_2 + b_3h_3 + b_4h_4 + b_5h_5 + b_6h_6 + b_7h_7 + b_8h_8$$

$$\text{Area} \approx b_1f(.5) + b_2f(1) + b_3f(1.5) + b_4f(2) + b_5f(2.5) + b_6f(3) + b_7f(3.5) + b_8f(4) =$$

As you go through this process, several things should be apparent:

- Drawing the function is not really necessary.
- The more rectangles you create, the more work you have to do. It is just a lot of arithmetic.
- In each case, the base is same allowing you to factor it out. For instance in the last case above,

$$b_1f(.5) + b_2f(1) + b_3f(1.5) + b_4f(2) + b_5f(2.5) + b_6f(3) + b_7f(3.5) + b_8f(4) =$$

$$b [f(.5) + f(1) + f(1.5) + f(2) + f(2.5) + f(3) + f(3.5) + f(4)]$$

- The more rectangles you create, the more accurate the area should be. So it should be apparent that

$$\text{True Area} = \lim_{n \rightarrow \infty} \sum_{i=1}^n A_i$$

Examples) Find the area under the following functions using the indicated number of rectangles:

1) $f(x) = 3x + 1$ on $[1,5]$

2. $f(x) = x^2 + 3$ on $[2,5]$

3. $f(x) = x^2 - 3x - 2$ on $[4,6]$

a) 4

b) 8

a) 3

b) 6

a) 8

Riemann Sums - Classwork

As a common example, this worksheet will use this problem. Find the area under the function $f(x)$ given in the picture below from $x = 1$ to $x = 5$. What we are looking for is the picture on the right. We will look at 4 techniques: right rectangles, left rectangles, midpoint rectangles and trapezoids.

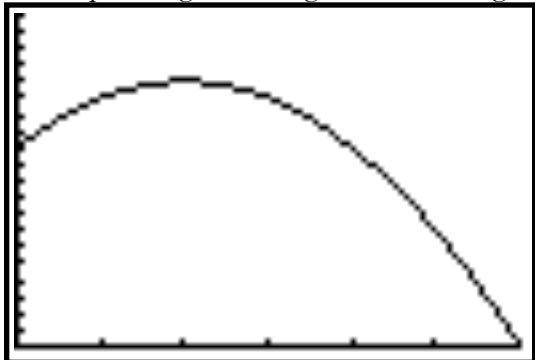

First some common statements. We will use 4 rectangles or trapezoids in this worksheet but you are expected to learn the technique for any number of rectangles or trapezoids. Obviously, if we wish 4 rectangles and the values of x run from 1 to 5, the base of each rectangle is 1. Here are the 4 pictures of what we are looking for.

Right rectangles



The height of the rectangle is on the right side.
This will underestimate the area (this case only).

Left rectangles

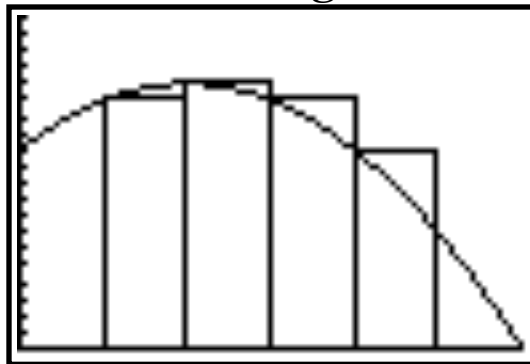

The height of the rectangle is on the left side.
This will overestimate the area (this case only).

Midpoint rectangles

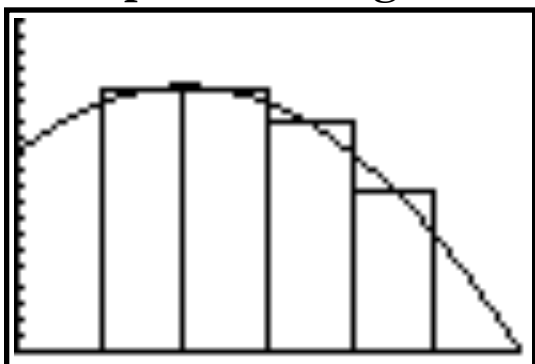

The height of the rectangle is in the middle.
This ends up both over and underestimating the area.

Trapezoids

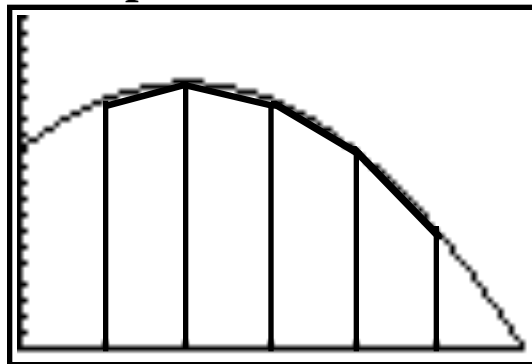

The vertical lines represent the bases of the trapezoids
The result is a very good approximation to the area.

When we divide our picture into 4 rectangles, we have to find the base of each rectangle. In this case, since we were interested in doing this from $x = 1$ to $x = 5$, and there were 4 rectangles, we lucked out because the base of each rectangle is 1. That won't always happen. In general, let's call the base = b .

Now let us define $x_0, x_1, x_2, x_3, \dots, x_n$ as the places on the x -axis where we will build our heights, where n represents the number of rectangles (or trapezoids). In this case,

$$x_0 = 1, x_1 = 2, x_2 = 3, x_3 = 4, x_4 = 5.$$

In the case of **left** rectangles, the area will be:

$$A \approx bh_0 + bh_1 + bh_2 + bh_3$$

$$A \approx b(h_0 + h_1 + h_2 + h_3)$$

but since $h_i = f(x_i)$, we can say

$$A \approx b(f(x_0) + f(x_1) + f(x_2) + f(x_3))$$

so, in the specific case above

$$A \approx 1(f(1) + f(2) + f(3) + f(4))$$

so in general:

$$A \approx b \sum_{i=0}^{n-1} f(x_i)$$

In the case of **right** rectangles, the area will be:

$$A \approx bh_1 + bh_2 + bh_3 + bh_4$$

$$A \approx b(h_1 + h_2 + h_3 + h_4)$$

$$A \approx b(f(x_1) + f(x_2) + f(x_3) + f(x_4))$$

$$A \approx 1(f(2) + f(3) + f(4) + f(5))$$

$$A \approx b \sum_{i=1}^n f(x_i)$$

These are called Riemann Sums.

In the case of **midpoint rectangles**, you have to find the midpoint between your $x_0, x_1, x_2, x_3, \dots, x_n$. The midpoint between any two x values is their sum divided by 2, so you will use:

$$A \approx b \left[f\left(\frac{(x_0 + x_1)}{2}\right) + f\left(\frac{(x_1 + x_2)}{2}\right) + f\left(\frac{(x_2 + x_3)}{2}\right) + f\left(\frac{(x_3 + x_4)}{2}\right) \right]$$

$$\text{In our case, } A \approx 1 \left[f\left(\frac{(1+2)}{2}\right) + f\left(\frac{(2+3)}{2}\right) + f\left(\frac{(3+4)}{2}\right) + f\left(\frac{(4+5)}{2}\right) \right] \text{ or } A \approx 1(f(1.5) + f(2.5) + f(3.5) + f(4.5))$$

For **trapezoids**, remember that area $A = \frac{1}{2} \cdot \text{height} \cdot (b_1 + b_2)$. That is when the trapezoid looks like this:

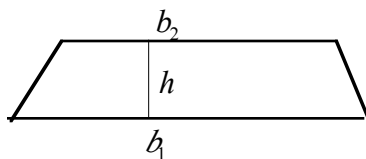

Since our trapezoids are on their sides, we will say

$$A = \frac{1}{2} \cdot \text{base} \cdot (h_1 + h_2)$$

$$\text{So, the total area } A \approx \frac{1}{2}b \left[(f(x_0) + f(x_1)) + (f(x_1) + f(x_2)) + (f(x_2) + f(x_3)) + (f(x_3) + f(x_4)) \right]$$

$$\text{or, in our case } A \approx \frac{1}{2}b \left[f(x_0) + 2f(x_1) + 2f(x_2) + 2f(x_3) + f(x_4) \right] = \frac{1}{2}b \left[f(1) + 2f(2) + 2f(3) + 2f(4) + f(5) \right]$$

$$\text{In general, the trapezoidal rule: } \boxed{A \approx \frac{1}{2}b \left[f(x_0) + 2f(x_1) + 2f(x_2) + 2f(x_3) + \dots + 2f(x_{n-1}) + f(x_n) \right]}$$

Let's try one: Let $f(x) = x^2 - 3$. We want to find the area under the curve using 8 rectangles/trapezoids from $x = 2$ to $x = 6$. First, let's draw it. Note that the curve is completely above the axis. If it dips below, the method changes slightly.

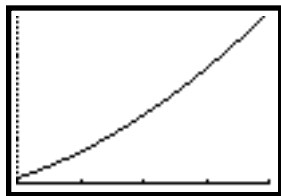

The drawing of the curve is helpful, but not necessary.

Since there are 8 rectangles, and we are finding the area between $x = 2$ and $x = 6$, the base is _____

Let's complete the chart:

i	x_i	$f(x_i)$
0		
1		
2		
3		
4		
5		
6		
7		
8		

So, the right rectangle formula gives _____

the left rectangle formula give _____

the trapezoid formula gives _____

Note that the chart will not give you the midpoint formula. Let's do it here:

The calculator can generate this chart. Let's use right rectangles. Go to **STAT** EDIT and clear out L1 and L2.

Place your x_i in L1. It will look like this: Now L2 contains $f(x_i)$. Since your function is in Y1, use

L1	L2	L3	Z
2.5			
3.5			
4.5			
5.5			

L2(1)=

L1	L2	L3	Z
2.5	3.25		
3.5	8.25		
4.5	13		
5.5	27.25		

L2=Y1(L1)

Now, you want to sum your L2 list and multiply it by your base which is .5. So go to your home screen and use:

.5sum(L2)	65.5
-----------	------

You will find the SUM command in your **LIST** MATH menu.

How do you adjust this for left rectangles? _____

Interpretation of Area

1. A car comes to a stop 5 seconds after the driver slams on the brakes. While the brakes are on, the following velocities are recorded. Estimate the total distance the car took to stop.

Time since brakes applied (sec)	0	1	2	3	4	5
Velocity (ft/sec)	88	60	40	25	10	0

2. You jump out of an airplane. Before your parachute opens, you fall faster and faster. Your acceleration decreases as you fall because of air resistance. The table below gives your acceleration a (in m/sec^2) after t seconds. Estimate the velocity after 5 seconds.

t	0	1	2	3	4	5
a	9.81	8.03	6.53	5.38	4.41	3.61

3. Cedarbrook golf course is constructing a new green. To estimate the area A of the green, the caretaker draws parallel lines 10 feet apart and then measures the width of the green along that line. Determine how many square feet of grass sod that must be purchased to cover the green if

- The caretaker is lazy and uses midpoint rectangles to calculate the area.
- The caretaker uses left rectangles to calculate the area.
- The caretaker uses right rectangles to calculate the area.
- The caretaker uses trapezoids to calculate the area.

Width in feet	0	28	50	62	60	55	51	30	3
---------------	---	----	----	----	----	----	----	----	---

Riemann Sums - Homework

For each problem, approximate the area under the given function using the specified number of rectangles/trapezoids. You are to do all 4 methods to approximate the areas.

#	Function	Interval	Number	Left Rectangles	Right Rectangles	Midpoint Rectangles	Trapezoids
1	$f(x) = x^2 - 3x + 4$	[1,4]	6				
2	$f(x) = \sqrt{x}$	[2,6]	8				
3	$f(x) = 2^x$	[0,1]	5				
4	$f(x) = \sin x$	[0, π]	8				

Answers are below:

#	Left Rectangles	Right Rectangles	Midpoint Rectangles	Trapezoids
1	9.125	12.125	10.438	10.625
2	7.650	8.168	7.914	7.909
3	1.345	1.545	1.442	1.445
4	1.974	1.974	2.013	1.974

5. Roger decides to run a marathon. Roger's friend Jeff rides behind him on a bicycle and clocks his pace every 15 minutes. Roger starts out strong, but after an hour and a half he is so exhausted that he has to stop. The data Jeff collected is summarized below. Assuming that Roger's speed is always decreasing, estimate the distance that Roger ran in a) the first half hour and b) the entire race. (Trapezoids)

Time spent running (min)	0	15	30	45	60	75	90
Speed (mph)	12	11	10	10	8	7	0

6. Coal gas is produced at a gasworks. Pollutants in the air are removed by scrubbers, which become less and less efficient as time goes on. Measurements are made at the start of each month (although some months were neglected) showing the rate at which pollutants in the gas are as follows. Use trapezoids to estimate the total number of tons of coal removed over 9 months.

Time (months)	0	1	3	4	6	7	9
Rate pollutants are escaping (tons/month)	5	7	8	10	13	16	20

7. For $0 \leq t \leq 1$, a bug is crawling at a velocity v , determined by the formula $v = \frac{1}{1+t}$, where t is in hours and v is in meters/hr. Find the distance that the bug crawls during this hour using 10 minute increments.

8. An object has zero initial velocity and a constant acceleration of 32 ft/sec^2 . Complete the chart to find the velocity at these specified times. Then determine the distance traveled in 4 seconds.

t (sec)	0	.5	1	1.5	2	2.5	3	3.5	4
v (ft/sec)									